

Job Name: _____

Location: _____

Engineer: _____

Submitted to: _____

Submitted by: _____

Reference: _____

Date: _____

Approval: _____

Construction: _____

Unit #: _____

Drawing #: _____

KEY FEATURES:

- Two-way Draining Connection
- Activated Carbon Filter
- GoldFin Anti-Corrosive Coating
- Omni-Directional Airflow
- 12 Indoor Fan Speeds
- Refrigerant Leakage Detection
- Self Diagnosis Function
- Fresh Air Intake

NOTES:



CEILING CASSETTE



Indoor Model			CH-N36LCCT-230VI
Power supply		V, Ph, Hz	208-230V, 1Ph, 60Hz
Communication wiring			14AWG*2 Stranded, shielded
Cooling	Capacity	Btu/h	36,000(12,400~36,000)
	Input	w	3,830(477~4,000)
	Rated current	A	17.39(3.33~17.39)
	EER/EER2	Btu/w	9.4
	SEER/SEER2	Btu/w	19.2
Heating at 47 °F	Capacity	Btu/h	38,000(11,200~38,000)
	Input	W	3,500(666~3,700)
	Rated current	A	15.55(3.72~16.93)
	COP	W/W	3.18
	HSPF4/HSPF2-4		8.8
	HSPF5/HSPF2-5		7
Indoor fan motor		Qty	1
		Input	157
		RLA	1
Indoor air flow (Turbo/Hi/Med/Lo) (No duct)		CFM	1,041.18/947.06/852.94/752.94
ESP (range)		In.wg.	
Indoor noise level (Hi/Med/Lo)		dB(A)	52.5/50/46.5
Dehumidification		L/H	9.55
Indoor unit	Dimensions (WxDxH)	inch	32.68x32.68x9.65
	Packing (WxDxH)	inch	35.83x35.83x11.42
	Net/Gross weight	lbs	59.97/69.00
Drainage water pipe diameter		inch	1"
Refrigerant piping (Liquid side/Gas side)		inch	3/8"/5/8"
Design pressure		PSIG	550/340
Controller			RG10K-exclusive remote&120X or 120N wire controller
Room temperature	Cooling	F	60~90
	Heating	F	32~86

Outdoor Model			CH-36LCU/O
Power supply		V, Ph, Hz	208-230V, 1Ph, 60Hz
Min. circuit ampacity		A	30
Max. fuse		A	45
Compressor	Model		KTF310D43UMT
	Type		ROTARY
	Brand		GMCC
	Capacity	Btu/h	34,150
	Input	w	2.765
	Rated current (RLA)	A	23.5
	Refrigerant oil	oz	VG74 33.8
Outdoor fan motor	Qty		1
	Input	w	150
	RLA	A	1.35
	Speed	r/min	950/800/500
Outdoor air flow (Max)		CFM	3,000
Outdoor noise level (Max)		dB(A)	63.5
Throttle type			EXV+Throttle valve
Outdoor unit	Dimensions (WxDxH)	inch	37.24x16.14x31.89
	Packing (WxDxH)	inch	42.91x19.69x34.84
	Net/Gross weight	inch	155.42/166.23
Refrigerant	Type		R410A
	Precharge	ft	25
Additional charge for 1/4 inch liquid pipe		oz	
Additional charge for 3/8 inch liquid pipe		oz	0.32
Refrigerant piping	Liquid side/Gas side	inch	3/8"/5/8"
	Max. pipe length	ft	213.25
	Max. difference in level	ft	98.42
Ambient temperature	Cooling	F	5~122
	Heating	F	5~75

CH-N36LCCT-230VI

CEILING CASSETTE

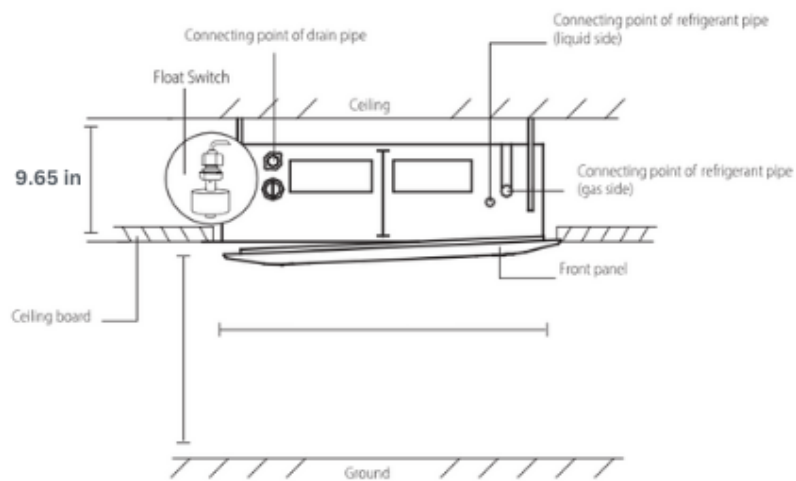
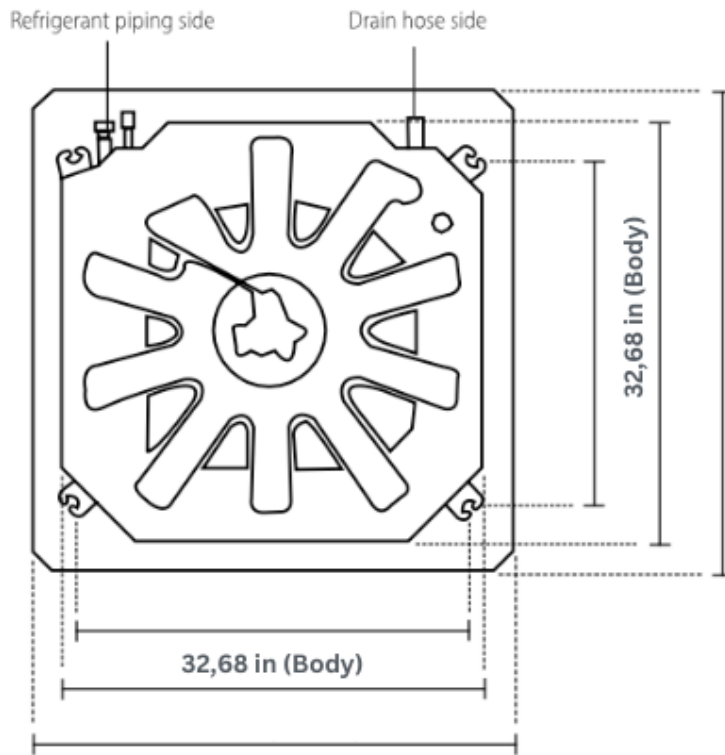

32.68x32.68x9.65

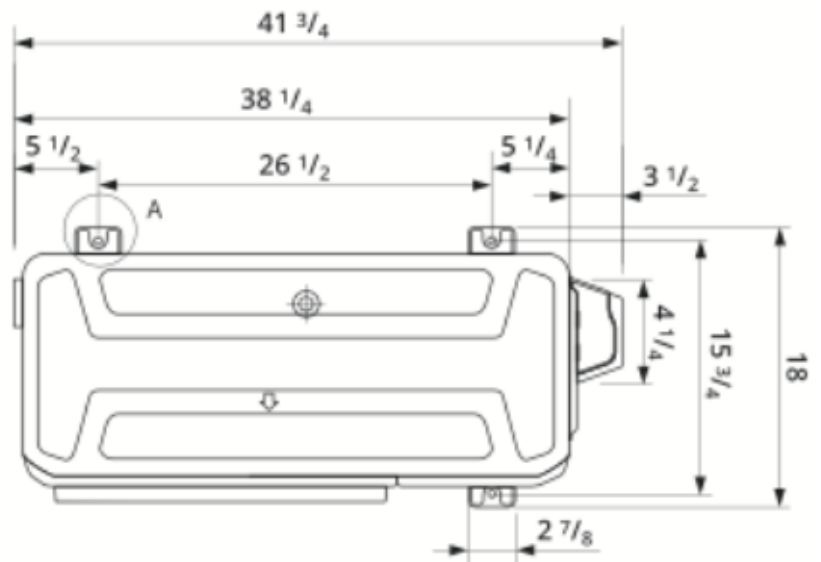
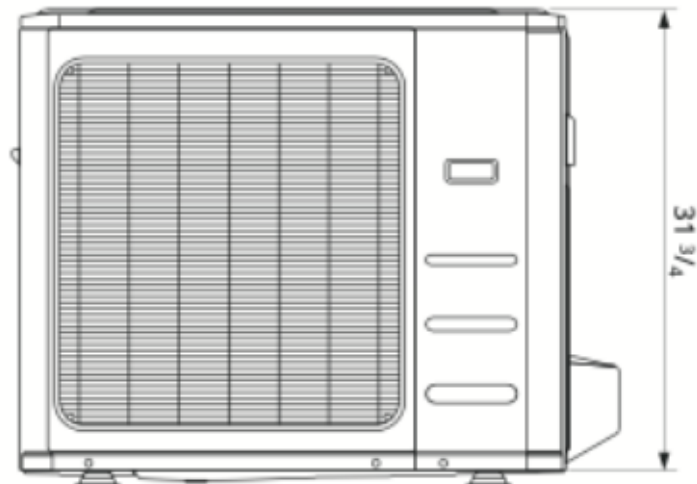
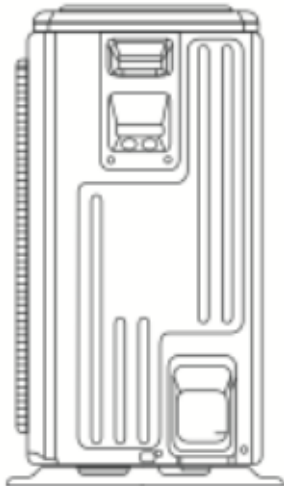

**DETAIL A
SCALE 1:1**

