



Installation Manual

MULTI-ZONE MINI SPLIT AC WITH HEAT PUMP

CH-18MES-230VO
CH-28MES-230VO
CH-36MES-230VO
CH-48MES-230VO
CH-55MES-230VO

CH-HPR19M-230VO
CH-HPR28M-230VO
CH-HPR36M-230VO
CH-HPR48M-230VO
CH-HPR55M-230VO

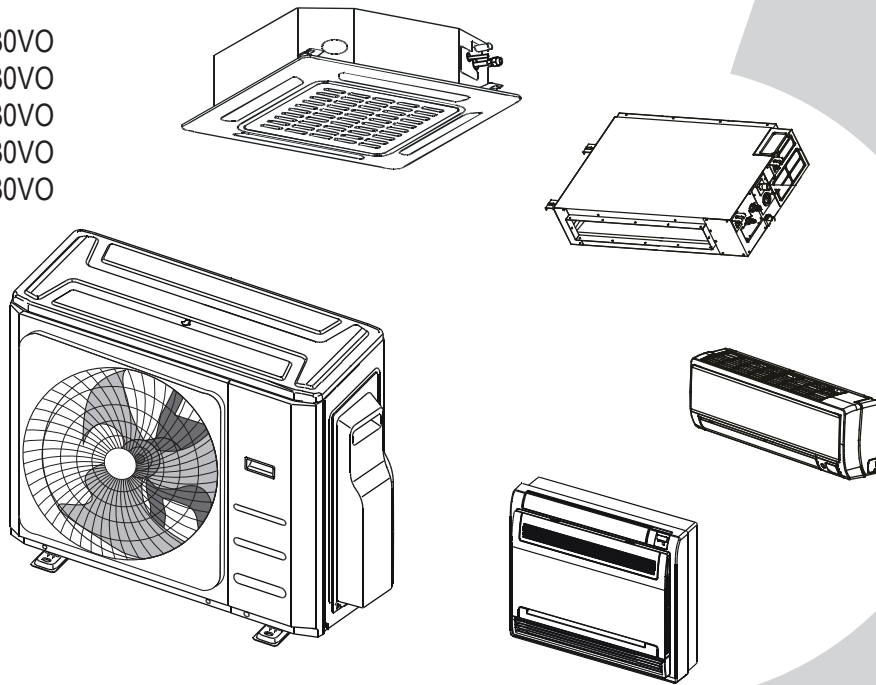

IMPORTANT NOTE:







Read this manual carefully before installing or operating your new air conditioning unit. Make sure to save this manual for future reference.

Installation Manual

Accessories	3
Installation Summary	4
Installation Diagram	5
Specifications	6
Outdoor Unit Installation	7
1. Select installation location	7
2. Install drain joint	8
3. Anchor outdoor unit.....	8
Refrigerant Piping Connection	10
1. Cut pipe	10
2. Remove burrs	10
3. Flare pipe ends	10
4. Connect pipes	11
Wiring	13
1. Outdoor Unit Wiring	15
2. Wiring Figure.....	17
Air Evacuation	24
Test Run	26
Function of Automatic Wiring/Piping Correction	27

Accessories

The air conditioning system comes with the following accessories. Use all of the installation parts and accessories to install the air conditioner. Improper installation may result in water leakage, electrical shock and fire, or cause the equipment to fail. The items are not included with the air conditioner must be purchased separately.

Name of Accessories	Q'ty(pc)	Shape	Name of Accessories	Q'ty(pc)	Shape
Manual	2~4		Drain joint (some models)	1	
Installation plate (some models)	1		Seal ring (some models)	1	
Plastic expansion sheath (some models)	5-8 (depending on models)		Magnetic ring (Hitch it on the connective cable between indoor unit and outdoor unit after installation.) (some models)	Varies by model	
Self-Tapping Screw A (some models)	5-8 (depending on models)				
Transfer connector (packed with the indoor or outdoor unit, depending on models) NOTE: Pipe size may differ from appliance to appliance. To meet different pipe size requirements, sometimes the pipe connections need a transfer connector installed on the outdoor unit .	Optional part (one piece/ one indoor unit) Optional part (1-5 pieces for outdoor unit, depending on models)		Cord protection rubber ring (If the cord clamp cannot fasten on a small cord, use the cord protection rubber ring [supplied with accessories] to wrap around the cord. Then fix it in place with the cord clamp.) (some models)	1	

Accessories

Optional accessories

- There are two types of remote controls: wired and wireless. Select a remote controller based on customer preferences and requirements and install in an appropriate place. Refer to catalogues and technical literature for guidance on selecting a suitable remote controller.

Name	Shape	Quantity(PC)	
Connecting pipe assembly	Liquid side	Φ 1/4 in(6.35)	Parts you must purchase separately. Consult the dealer about the proper pipe size of the unit you purchased.
		Φ 3/8 in(9.52)	
	Gas side	Φ 3/8 in(9.52)	
		Φ 1/2 in(12.7)	
		Φ 5/8 in(16)	

Installation Summary

INSTALLATION ORDER

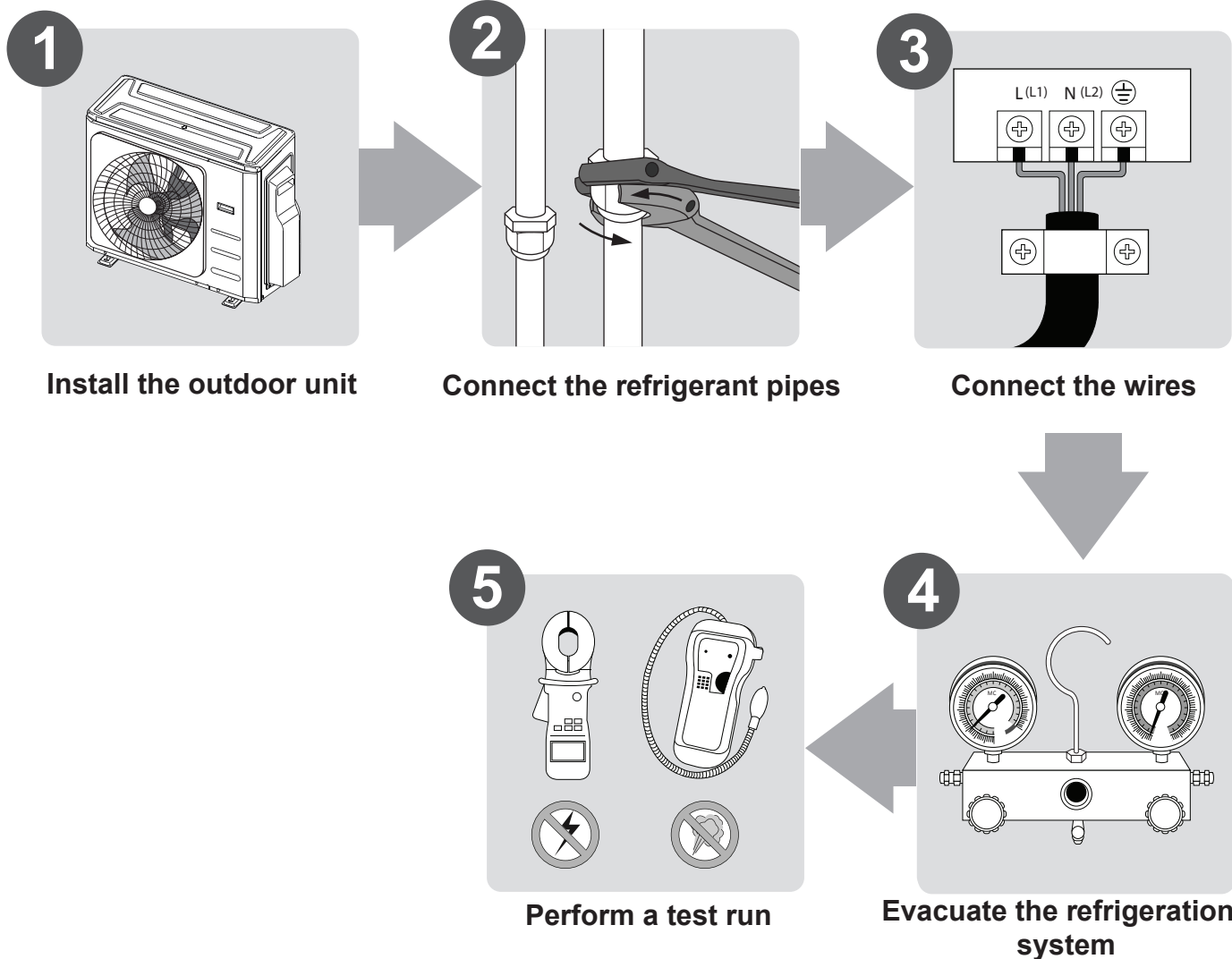

Specifications

Number of units that can be used together	Connected units	1-5 units
Compressor stop/start frequency	Stop time	3 min or more
Power source voltage	voltage fluctuation	within $\pm 10\%$ of rated voltage
	voltage drop during start	within $\pm 15\%$ of rated voltage
	interval unbalance	within $\pm 3\%$ of rated voltage

Unit: ft/m.

	1 drive 2	1 drive 3	1 drive 4	1 drive 5
Max. length for all rooms	131/40	60/197	80/262	80/262
Max. length for one indoor unit	82/25	30/98	35/115	35/115
Max. height different between indoor and outdoor unit	15/49	15/49	15/49	15/49
Max. height different between indoor units	10/33	10/33	10/33	10/33

NOTE: For the units adopt quick connectors, no more than two pipes can be connected, and the Max. length for each pipe is 24.6ft/7.5 m.

When installing multiple indoor units with a single outdoor unit, ensure that the length of the refrigerant pipe and the drop height between the indoor and outdoor units meet the requirements illustrated in the following diagram:

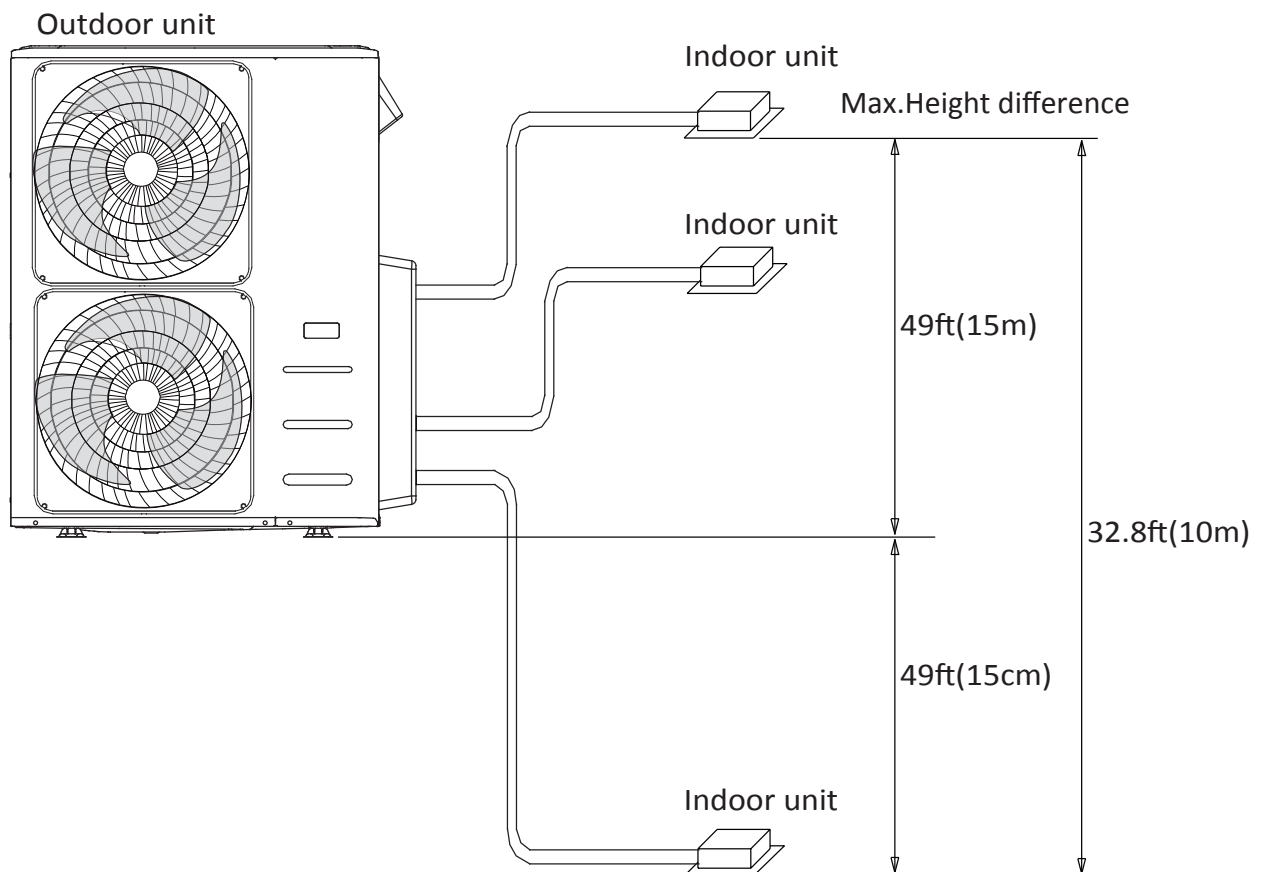

Outdoor Unit Installation

Install the unit by following local codes and regulations, there may be differ slightly between different regions.

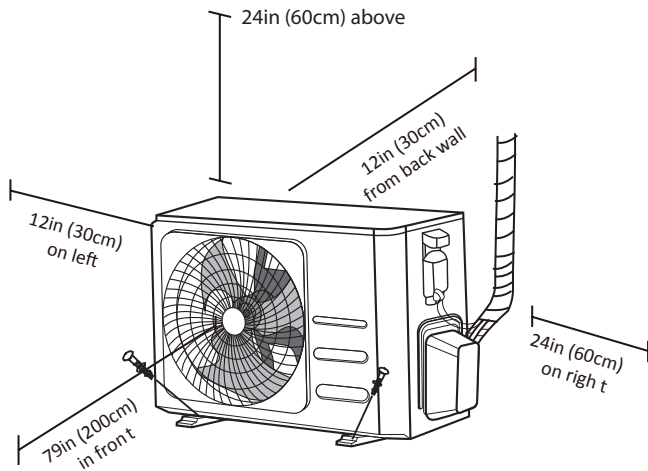

Installation Instructions – Outdoor unit

Step 1: Select installation location

Before installing the outdoor unit, you must choose an appropriate location. The following are standards that will help you choose an appropriate location for the unit.

Proper installation locations meet the following standards:

- ☑ Meets all spatial requirements shown in Installation Space Requirements above.
- ☑ Good air circulation and ventilation
- ☑ Firm and solid—the location can support the unit and will not vibrate
- ☑ Noise from the unit will not disturb others
- ☑ Protected from prolonged periods of direct sunlight or rain
- ☑ Where snowfall is anticipated, raise the unit above the base pad to prevent ice buildup and coil damage. Mount the unit high enough to be above the average accumulated area snowfall. The minimum height must be 18 inches

DO NOT install unit in the following locations:

- ⊘ Near an obstacle that will block air inlets and outlets
- ⊘ Near a public street, crowded areas, or where noise from the unit will disturb others
- ⊘ Near animals or plants that will be harmed by hot air discharge
- ⊘ Near any source of combustible gas
- ⊘ In a location that is exposed to large amounts of dust
- ⊘ In a location exposed to a excessive amounts of salty air

SPECIAL CONSIDERATIONS FOR EXTREME WEATHER

If the unit is exposed to heavy wind:

Install unit so that air outlet fan is at a 90° angle to the direction of the wind. If needed, build a barrier in front of the unit to protect it from extremely heavy winds. See Figures below.

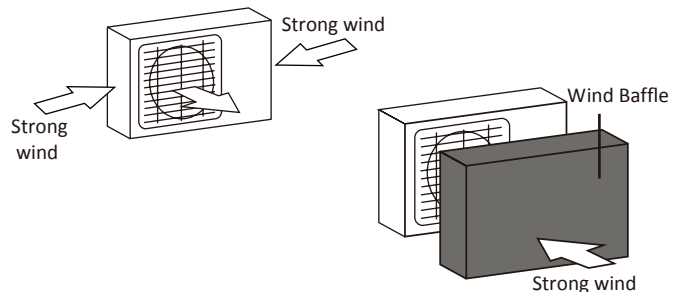

If the unit is frequently exposed to heavy rain or snow:

Build a shelter above the unit to protect it from the rain or snow. Be careful not to obstruct air flow around the unit.

If the unit is frequently exposed to salty air (seaside):

Use outdoor unit that is specially designed to resist corrosion.

Step 2: Install drain joint (Heat pump unit only)

Before bolting the outdoor unit in place, you must install the drain joint at the bottom of the unit. Note that there are two different types of drain joints depending on the type of outdoor unit.

If the drain joint comes with a rubber seal (see **Fig. A**), do the following:

1. Fit the rubber seal on the end of the drain joint that will connect to the outdoor unit.
2. Insert the drain joint into the hole in the base pan of the unit.
3. Rotate the drain joint 90° until it clicks in place facing the front of the unit.
4. Connect a drain hose extension (not included) to the drain joint to redirect water from the unit during heating mode.

If the drain joint doesn't come with a rubber seal (see **Fig. B**), do the following:

1. Insert the drain joint into the hole in the base pan of the unit. The drain joint will click in place.
2. Connect a drain hose extension (not included) to the drain joint to redirect water from the unit during heating mode.

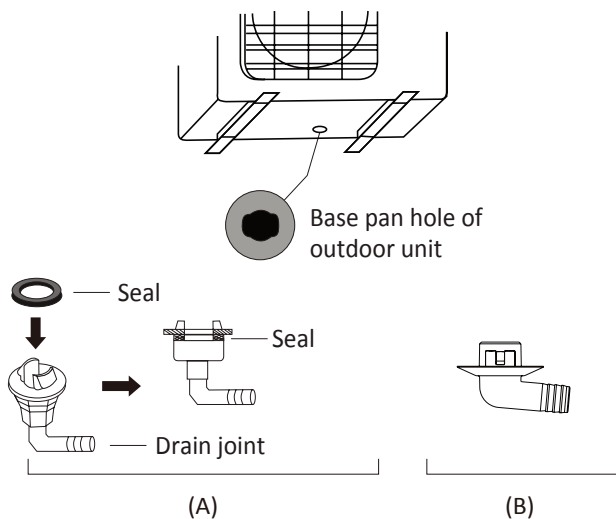

! IN COLD CLIMATES

In cold climates, make sure that the drain hose is as vertical as possible to ensure swift water drainage. If water drains too slowly, it can freeze in the hose and flood the unit.

Step 3: Anchor outdoor unit

The outdoor unit can be anchored to the ground or to a wall-mounted bracket with bolt(M10). Prepare the installation base of the unit according to the dimensions below.

UNIT MOUNTING DIMENSIONS

The following is a list of different outdoor unit sizes and the distance between their mounting feet. Prepare the installation base of the unit according to the dimensions below.

Outdoor Unit Types and Specifications

Split Type Outdoor Unit

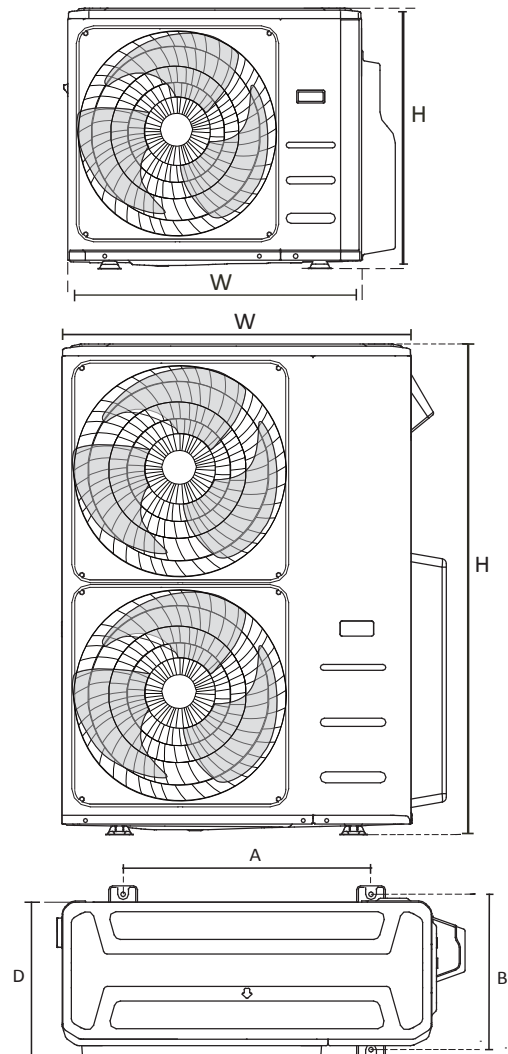

(unit: inch/mm)

Outdoor Unit Dimensions W x H x D	Mounting Dimensions	
	Distance A	Distance B
29.9x23.2x11.2in 760x590x285mm	20.85 (530)	11.4 (290)
31.9x22x12.2in 810x558x310mm	21.6 (549)	12.8 (325)
33.27x27.5x12.6 845x700x320mm	22 (560)	13.2 (335)
35.4x33.85x12.4in 900x860x315mm	23.2 (530)	13.1 (333)
37.2x31.9x15.55in 945x810x395mm	25.2 (640)	15.95 (405)
38.98x38x13.58in 990x965x345mm	24.58 (624)	14.4 (344)
36.93x53.9x15.43in 938x1369x392mm	24.96 (634)	15.9 (404)
35.4x46x13.8in 900x1170x350mm	23.2 (590)	14.88 (378)
31.5x21.8x13.1in 800x554x333mm	20.24 (514)	13.39 (340)
33.27x27.6x14.3in 845x702x363mm	21.26 (540)	13.8 (350)
37.2x31.9x16.53in 946x810x420mm	26.5 (673)	15.87 (403)
37.2x31.9x16.14in 946x810x410mm	26.5 (673)	15.87 (403)
37.5x52.5x16.14in 952x1333x410mm	24.96 (634)	15.9 (404)
37.5x52.5x16.14in 952x1333x415mm	24.96 (634)	15.9 (404)
35.0x 26.5x 13.5in 890x673x342mm	26.1 (663)	13.9 (354)

Rows of series installation

The relations between H, A and L are as follows.

	L	A
L ≤ H	L ≤ 1/2H	9.8" / 25cm or more
	1/2H < L ≤ H	11.8" / 30cm or more
L > H	Can not be installed	

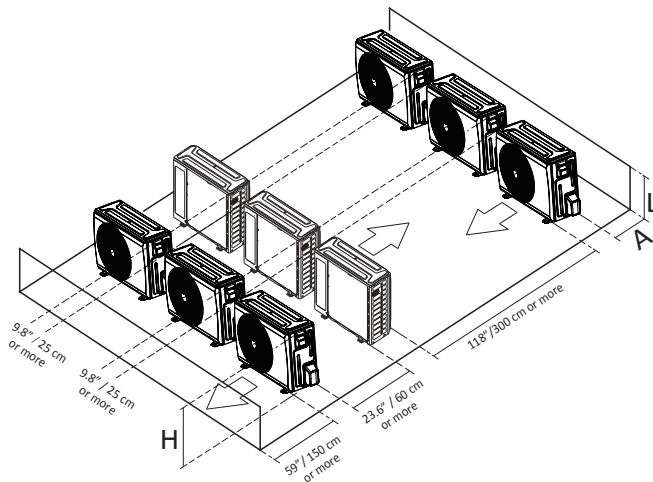

Notes On Drilling Hole In Wall

You must drill a hole in the wall for the refrigerant piping, and the signal cable that will connect the indoor and outdoor units.

1. Determine the location of the wall hole based on the location of the outdoor unit.
2. Using a 2.5" (65mm) core drill, drill a hole in the wall.

NOTE: When drilling the wall hole, make sure to avoid wires, plumbing, and other sensitive components.

3. Place the protective wall cuff in the hole. This protects the edges of the hole and helps seal it when you finish the installation process.

When Select a 24K Indoor Unit

The 24K indoor unit can only be connected with an A system. If there are two 24K indoor units, they can be connected with A and B systems.

Connective pipe size of an A and B system

(unit:inch)

Indoor Unit capacity (Btu/h)	Liquid	Gas
7K/9K/12K	1/4	3/8
12K/18K	1/4	1/2
24K	3/8	5/8

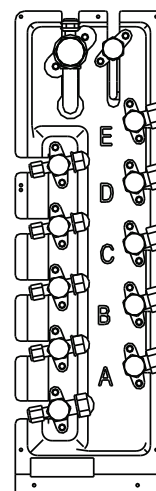

Outdoor Unit
Installation

Refrigerant Piping Connection

NOTE: For quick-connect models, please refer to the internal machine manual for the installation method of the connecting pipe. The external machine manual does not repeat the instructions.

When connecting refrigerant piping, **do not** let substances or gases other than the specified refrigerant enter the unit. The presence of other gases or substances will lower the unit's capacity, and can cause abnormally high pressure in the refrigeration cycle. This can cause explosion and injury.

Connection Instructions – Refrigerant Piping

⚠ CAUTION

- **DO NOT** install the connecting pipe until both indoor and outdoor units have been installed.
- Insulate both the gas and liquid piping to prevent water leakage.

Step 1: Cut pipes

When preparing refrigerant pipes, take extra care to cut and flare them properly. This will ensure efficient operation and minimize the need for future maintenance.

1. Measure the distance between the indoor and outdoor units.
2. Using a pipe cutter, cut the pipe a little longer than the measured distance.
3. Make sure that the pipe is cut at a perfect 90° angle.

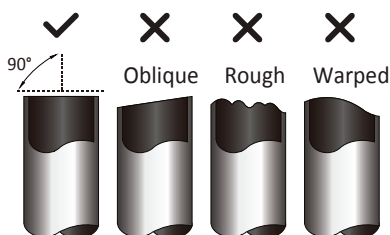

⊘ DO NOT DEFORM PIPE WHILE CUTTING

Be extra careful not to damage, dent, or deform the pipe while cutting. This will drastically reduce the heating efficiency of the unit.

Step 2: Remove burrs.

Burrs can affect the air-tight seal of refrigerant piping connection. They must be completely removed.

1. Hold the pipe at a downward angle to prevent burrs from falling into the pipe.
2. Using a reamer or deburring tool, remove all burrs from the cut section of the pipe.

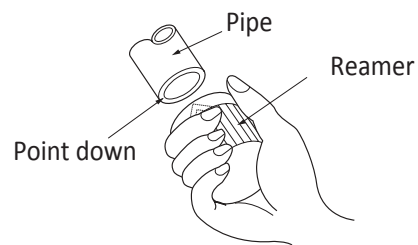

Step 3: Flare pipe ends

Proper flaring is essential to achieve an airtight seal.

1. After removing burrs from cut pipe, seal the ends with PVC tape to prevent foreign materials from entering the pipe.
2. Sheath the pipe with insulating material.
3. Place flare nuts on both ends of pipe. Make sure they are facing in the right direction, because you can't put them on or change their direction after flaring.

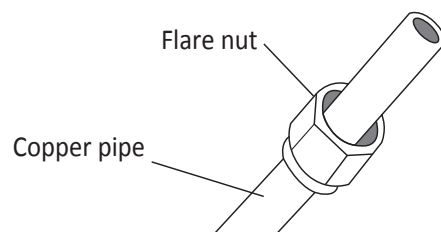

- Remove PVC tape from ends of pipe when ready to perform flaring work.
- Clamp flare form on the end of the pipe. The end of the pipe must extend beyond the flare form.

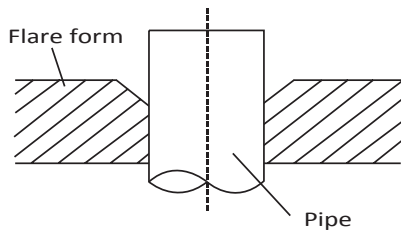

- Place flaring tool onto the form.
- Turn the handle of the flaring tool clockwise until the pipe is fully flared. Flare the pipe in accordance with the dimensions.

PIPING EXTENSION BEYOND FLARE FORM

Pipe gauge	Tightening torque	Flare dimension (A) (Unit: inch/mm)		Flare shape
		Min.	Max.	
∅ 6.4	18-20 N.m (183-204 kgf.cm)	0.33/8.4	0.34/8.7	
∅ 9.5	25-26 N.m (255-265 kgf.cm)	0.52/13.2	0.53/13.5	
∅ 12.7	35-36 N.m (357-367 kgf.cm)	0.64/16.2	0.65/16.5	
∅ 15.9	45-47 N.m (459-480 kgf.cm)	0.76/19.2	0.78/19.7	
∅ 19.1	65-67 N.m (663-683 kgf.cm)	0.91/23.2	0.93/23.7	
∅ 22	75-85 N.m (765-867 kgf.cm)	1.04/26.4	1.06/26.9	

- Remove the flaring tool and flare form, then inspect the end of the pipe for cracks and even flaring.

Step 4: Connect pipes

Connect the copper pipes to the indoor unit first, then connect it to the outdoor unit. You should first connect the low-pressure pipe, then the high-pressure pipe.

- When connecting the flare nuts, apply a thin coat of refrigeration oil to the flared ends of the pipes.
- Align the center of the two pipes that you will connect.

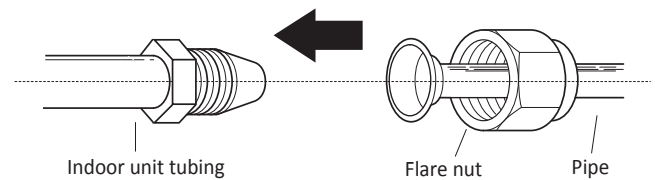

- Tighten the flare nut as tightly as possible by hand.
- Using a spanner, grip the nut on the unit tubing.
- While firmly gripping the nut, use a torque wrench to tighten the flare nut according to the torque values in above table.

NOTE: Use both a spanner and a torque wrench when connecting or disconnecting pipes to/from the unit.

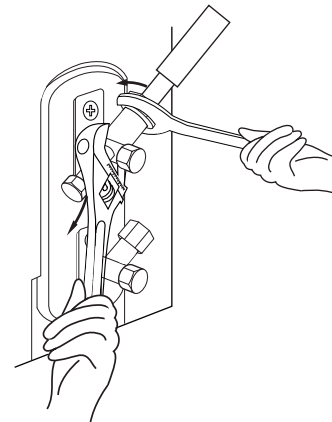

CAUTION

- Ensure to wrap insulation around the piping. Direct contact with the bare piping may result in burns or frostbite.
- Make sure the pipe is properly connected. Over tightening may damage the bell mouth and under tightening may lead to leakage.

NOTE ON MINIMUM BEND RADIUS

Carefully bend the tubing in the middle according to the diagram below. **DO NOT** bend the tubing more than 90° or more than 3 times.

Bend the pipe with thumb

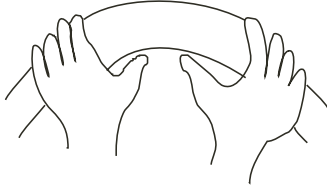

min-radius 3.9" (10cm)

6. After connecting the copper pipes to the indoor unit, wrap the power cable, signal cable and the piping together with binding tape.

NOTE: DO NOT intertwine signal cable with other wires. While bundling these items together, do not intertwine or cross the signal cable with any other wiring.

7. Thread this pipeline through the wall and connect it to the outdoor unit.
8. Insulate all the piping, including the valves of the outdoor unit.
9. Open the stop valves of the outdoor unit to start the flow of the refrigerant between the indoor and outdoor unit.

! CAUTION

Check to make sure there is no refrigerant leak after completing the installation work. If there is a refrigerant leak, ventilate the area immediately and evacuate the system (refer to the Air Evacuation section of this manual).

Wiring

! BEFORE PERFORMING ANY ELECTRICAL WORK, READ THESE REGULATIONS

1. All wiring must comply with local and national electrical codes, regulations and must be installed by a licensed electrician.
2. All electrical connections must be made according to the Electrical Connection Diagram located on the panels of the indoor and outdoor units.
3. If there is a serious safety issue with the power supply, stop work immediately. Explain your reasoning to the client, and refuse to install the unit until the safety issue is properly resolved.
4. Power voltage should be within 90-110% of rated voltage. Insufficient power supply can cause malfunction, electrical shock, or fire.
5. If connecting power to fixed wiring, a surgeprotector and main power switch should be installed.
6. If connecting power to fixed wiring, a switch or circuit breaker that disconnects all poles and has a contact separation of at least 1/8in (3mm) must be incorporated in the fixed wiring. The qualified technician must use an approved circuit breaker or switch.
7. Only connect the unit to an individual branch circuit outlet. Do not connect another appliance to that outlet.
8. Make sure to properly ground the air conditioner.
9. Every wire must be firmly connected. Loose wiring can cause the terminal to overheat, resulting in product malfunction and possible fire.
10. Do not let wires touch or rest against refrigerant tubing, the compressor, or any moving parts within the unit.
11. If the unit has an auxiliary electric heater, it must be installed at least 40in (1 meter) away from any combustible materials.
12. To avoid getting an electric shock, never touch the electrical components soon after the power supply has been turned off. After turning off the power, always wait 10 minutes or more before you touch the electrical components.

13. Make sure that you do not cross your electrical wiring with your signal wiring. This may cause distortion and interference.
14. The unit must be connected to the main outlet. Normally, the power supply must have a impedance of 32 ohms.
15. No other equipment should be connected to the same power circuit.
16. Connect the outdoor wires before connecting the indoor wires.

! WARNING

BEFORE PERFORMING ANY ELECTRICAL OR WIRING WORK, TURN OFF THE MAIN POWER TO THE SYSTEM.

NOTE ON AIR SWITCH

When the maximum current of the air conditioner is more than 16A, an air switch or leakage protection switch with protective device shall be used (purchased seperately) .

When the maximum current of the air conditioner is less than 16A, the power cord of air conditioner shall be equipped with plug (purchased seperately).

The North American market is wired according to NEC and CEC requirements.

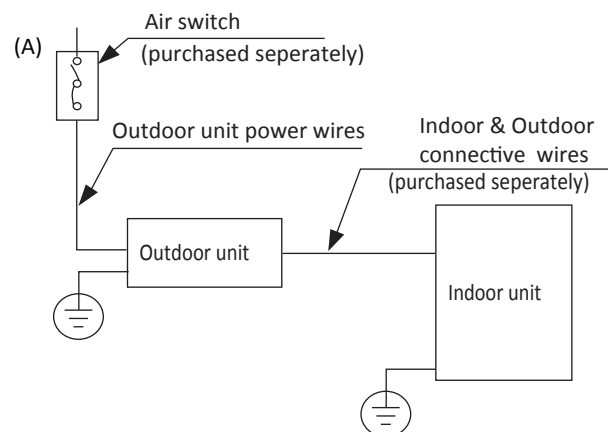

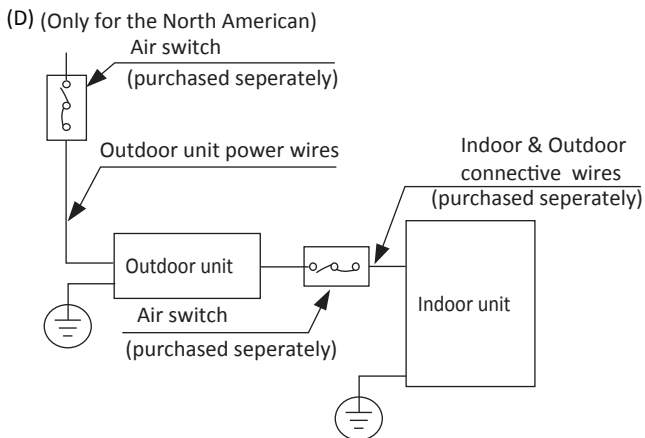
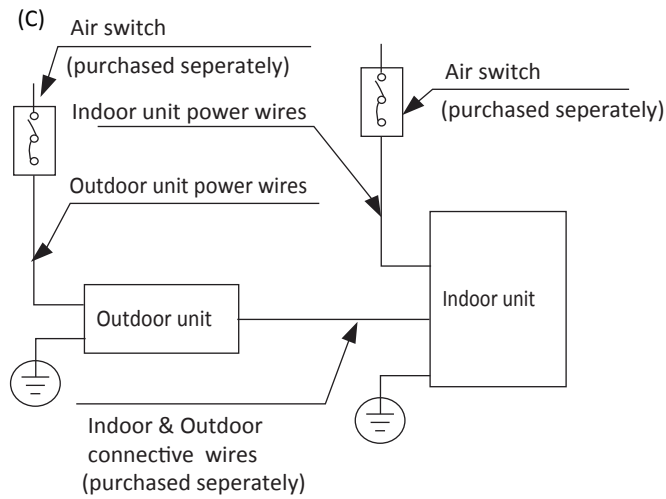
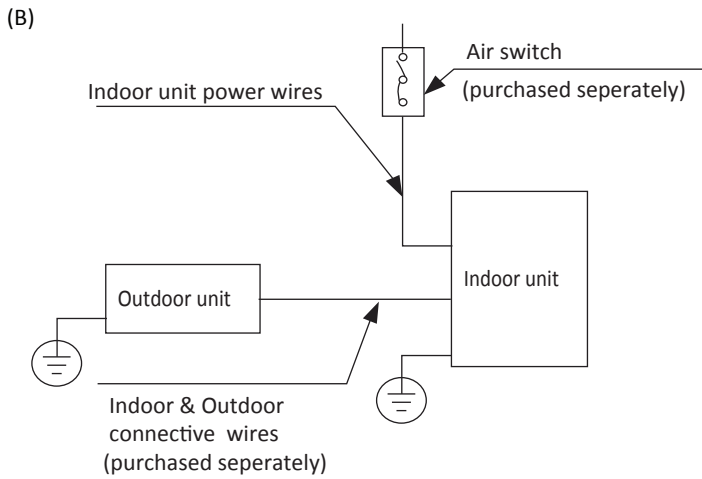

NOTE: The cognographs are for explanation purpose only. Your machine may be slightly different. The actual shape shall prevail.

Outdoor Unit Wiring

WARNING

Before performing any electrical or wiring work, turn off the main power to the system.

1. Prepare the cable for connection
 - a. You must first choose the right cable size. Be sure to use H07RN-F cables.

NOTE: In North America, choose the cable type according to the local electrical codes and regulations.

Minimum Cross-Sectional Area of Power and Signal Cables

North America

Appliance Amps (A)	AWG
10	18
13	16
18	14
25	12
30	10

CHOOSE THE RIGHT CABLE SIZE

The size of the power supply cable, signal cable, fuse, and switch needed is determined by the maximum current of the unit. The maximum current is indicated on the nameplate located on the side panel of the unit. Refer to this nameplate to choose the right cable, fuse, or switch.

NOTE: In North America, please choose the right cable size according to the Minimum Circuit Ampacity indicated on the nameplate of the unit.

- b. Using wire strippers, strip the rubber jacket from both ends of the signal cable to reveal approximately 5.9" (15cm) of wire.
- c. Strip the insulation from the ends.
- d. Using a wire crimper, crimp u-lugs on the ends.

NOTE: When connecting the wires, strictly follow the wiring diagram found inside the electrical box cover.

- Remove the electric cover of the outdoor unit. If there is no cover on the outdoor unit, take off the bolts from the maintenance board and remove the protection board.

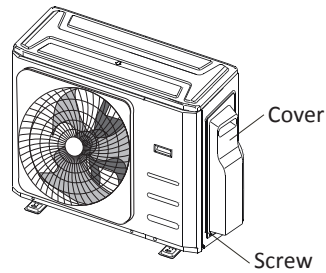

- Connect the u-lugs to the terminals Match the wire colors/labels with the labels on the terminal block, and firmly screw the u-lug of each wire to its corresponding terminal.
- Clamp down the cable with designated cable clamp.
- Insulate unused wires with electrical tape. Keep them away from any electrical or metal parts.
- Reinstall the cover of the electric control box.

Harmonic declaration

"The equipment CH-36MES230VO- complies with IEC 61000-3-12 provided that the shortcircuit power S_{sc} is greater than or equal to 4787737.5 at the interface point between the user's supply and the public system. It is the responsibility of the installer or user of the equipment to ensure, by consultation with the distribution network operator if necessary, that the equipment is connected only to a supply with a short-circuit power S_{sc} greater than or equal to 4787737.5."

"The equipment CH-48MES-230VO complies with IEC 61000-3-12 provided that the shortcircuit power S_{sc} is greater than or equal to 3190042.5 at the interface point between the user's supply and the public system. It is the responsibility of the installer or user of the equipment to ensure, by consultation with the distribution network operator if necessary, that the equipment is connected only to a supply with a short-circuit power S_{sc} greater than or equal to 3190042.5."

Wiring Figure

⚠ CAUTION

Connect the connective cables to the terminals, as identified, with their matching numbers on the terminal block of the indoor and outdoor units. For example, Terminal L1(A) of the outdoor unit must connect with terminal L1/1 on the indoor unit. The outdoor unit can match different types of indoor unit, the numbers on the terminal block of the indoor unit may be slightly different. Please pay special attention while connecting the wire.

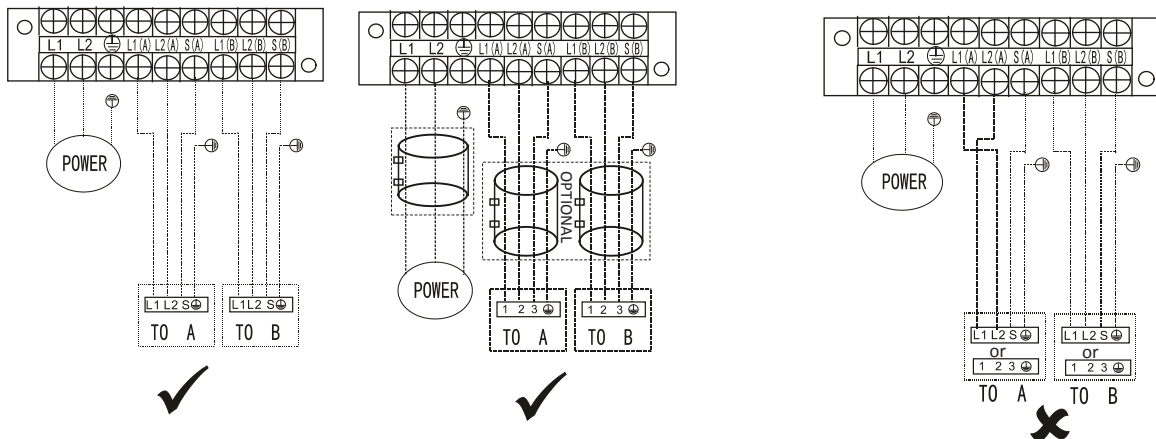

NOTE: For quick-connector models, please refer to <<Owner's Manual & Installation Manual >> packed with the indoor unit.

NOTE: Refer to the following figures if end-users wish to perform their own wiring.
 Run the main power cord through the lower line-outlet of the cord clamp.
 ---- This symbol indicates field wiring.

One-two models:

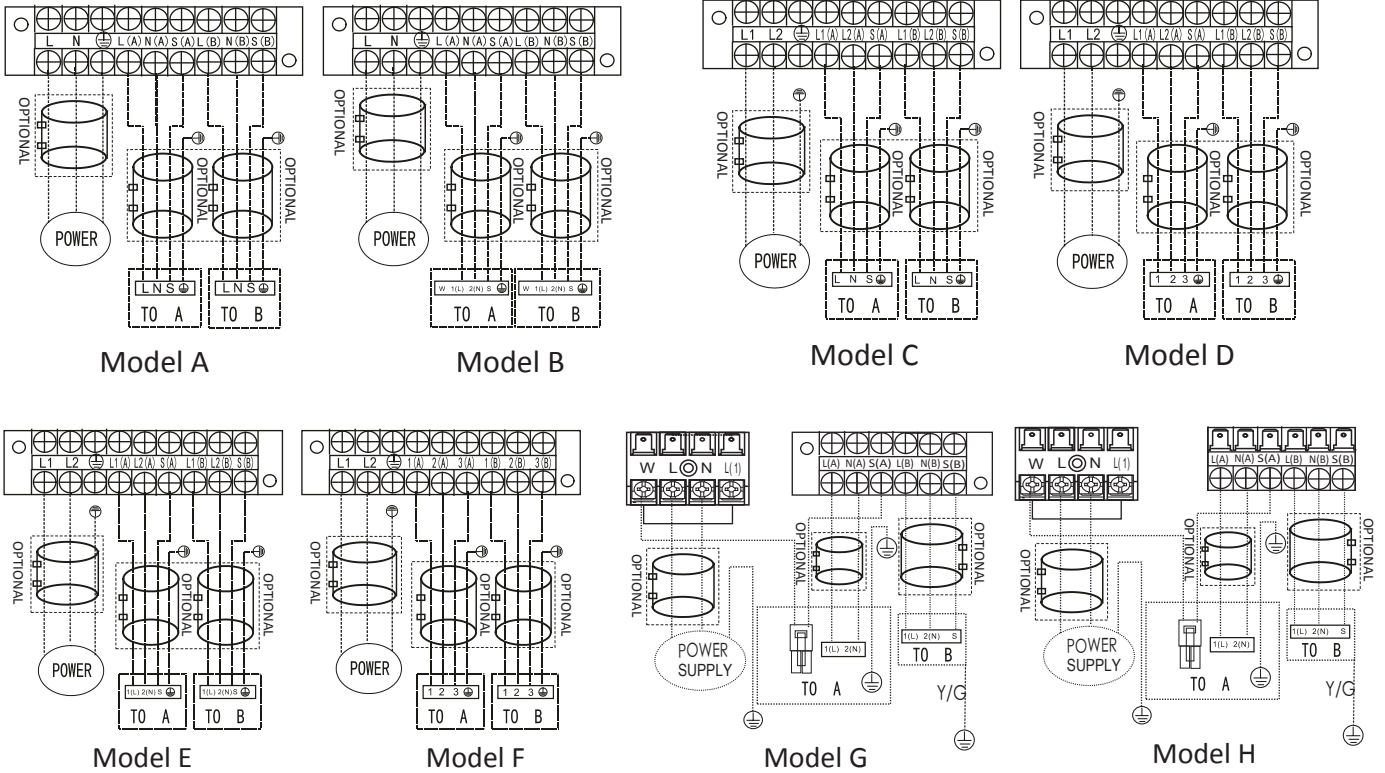

NOTE: Use the magnetic ring (not supplied, optional part) to hitch the connective cable of indoor and outdoor units after installation. One magnetic ring is used for one cable.

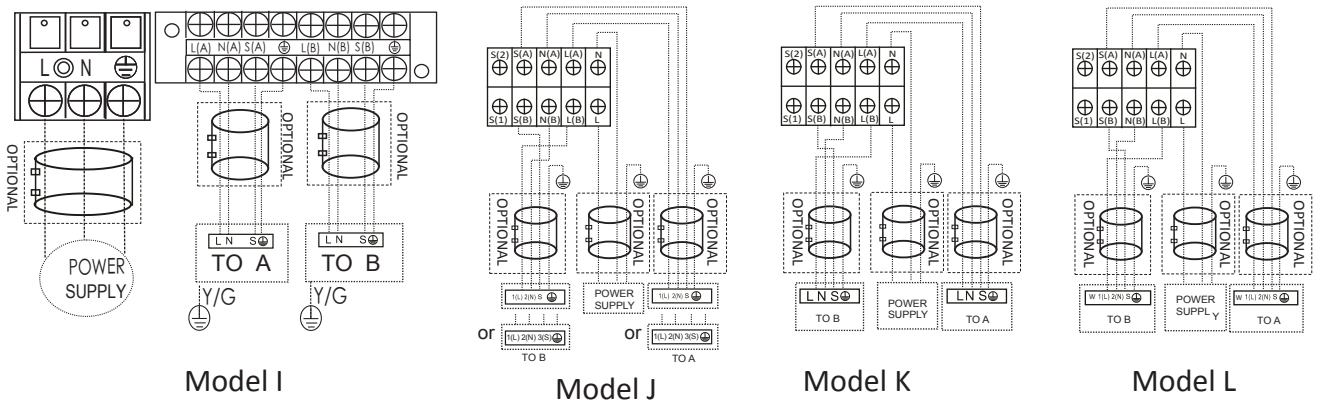

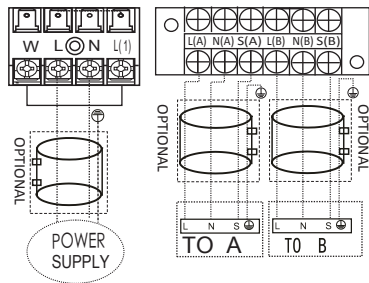

Model M

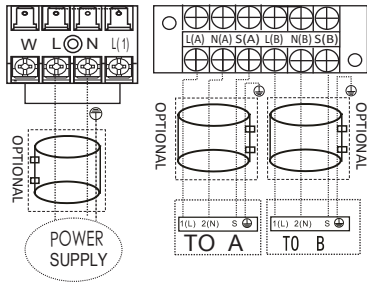

Model N

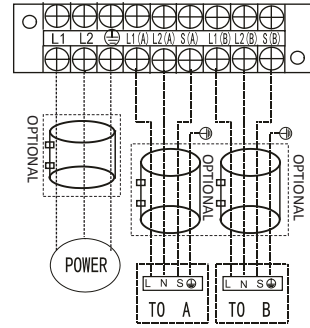

Model O

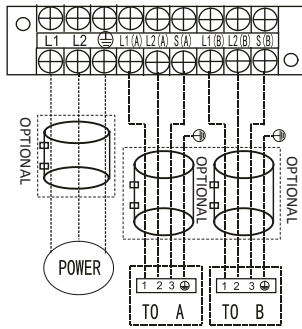

Model P

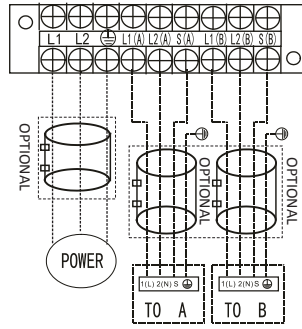

Model Q

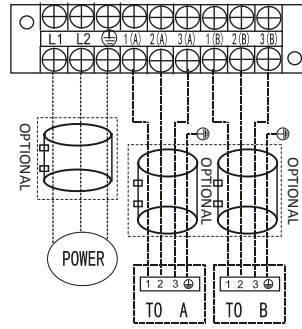

Model R

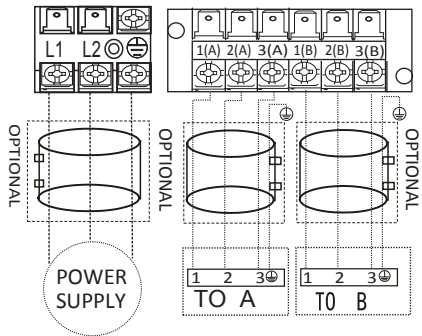

Model S

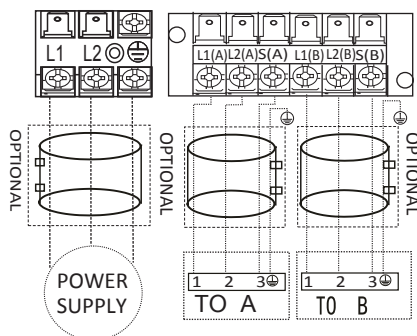

Model T

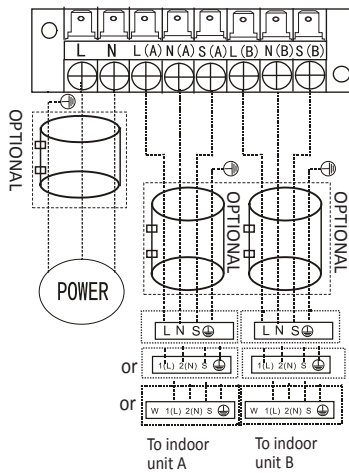

Model U

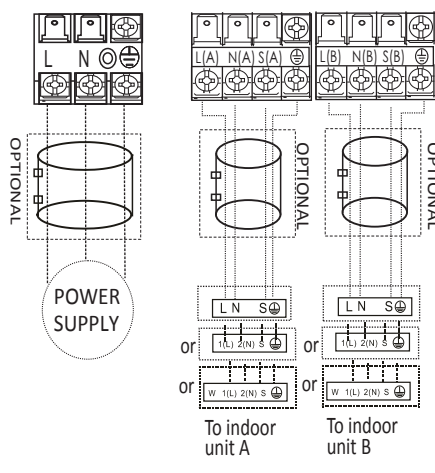

Model V

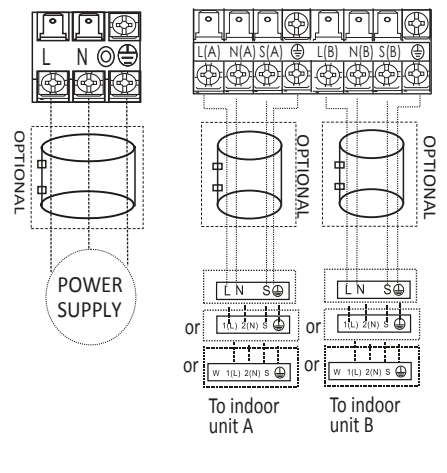

Model W

One-three models:

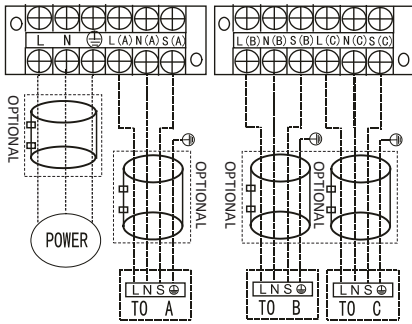

Model A

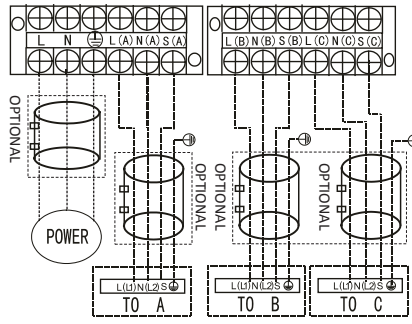

Model B

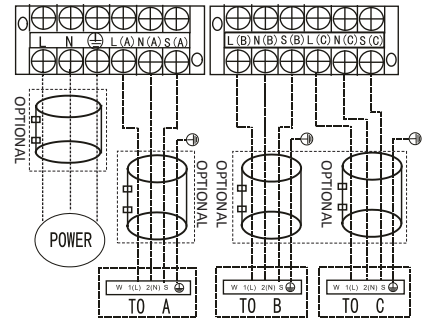

Model C

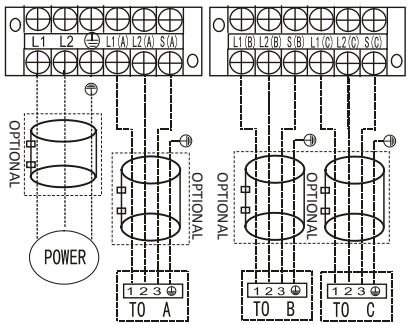

Model D

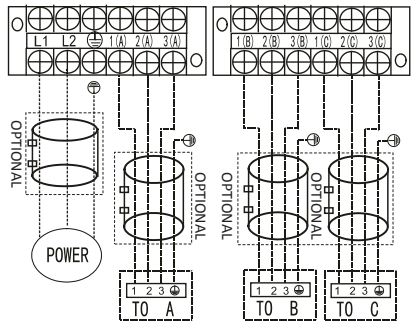

Model E

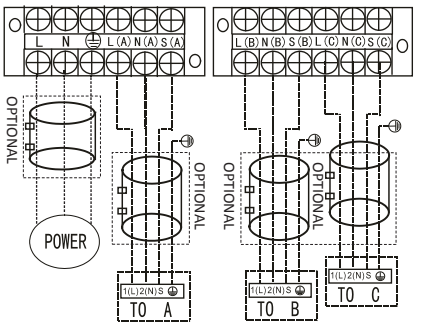

Model F

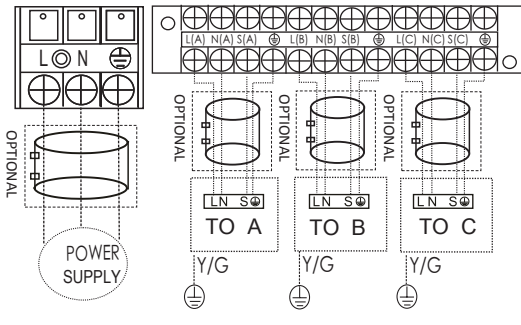

Model G

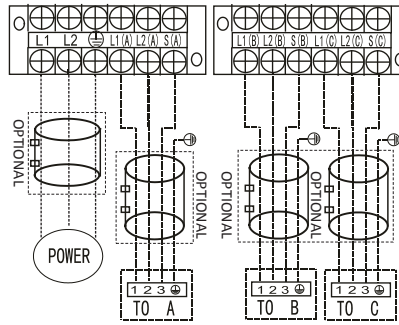

Model H

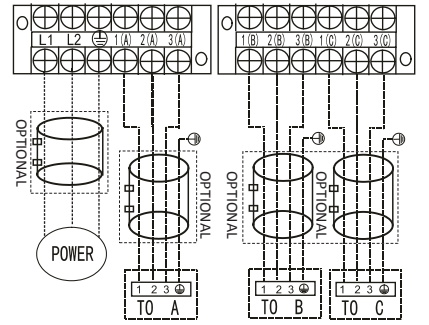

Model I

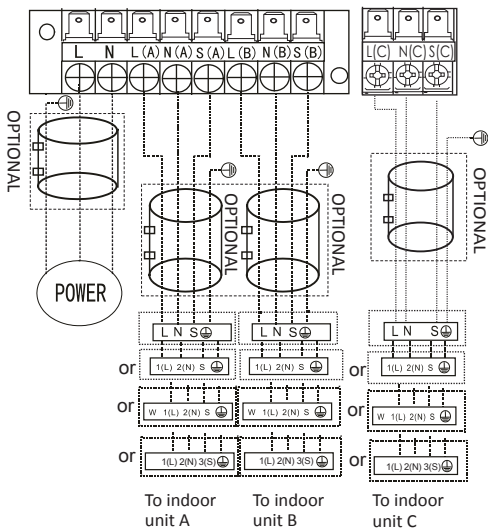

Model J

One-four models:

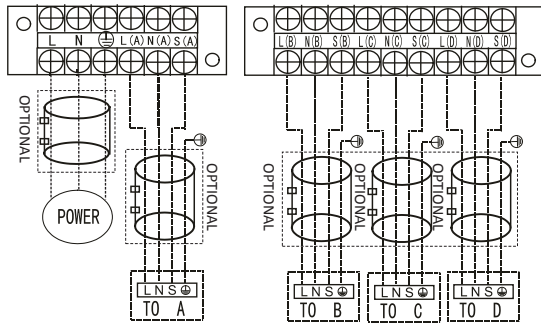

Model A

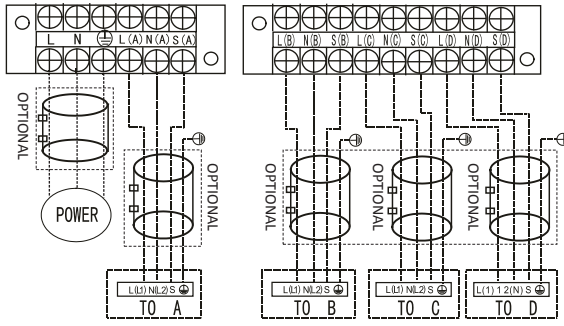

Model B

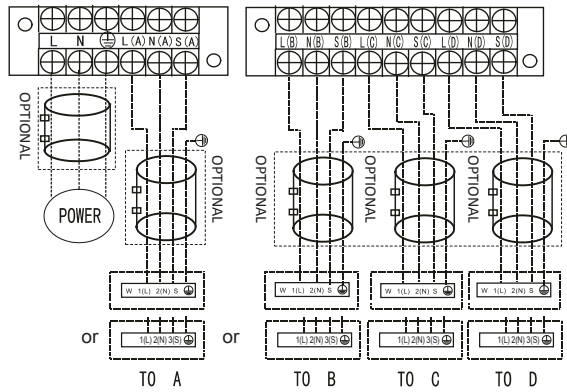

Model C

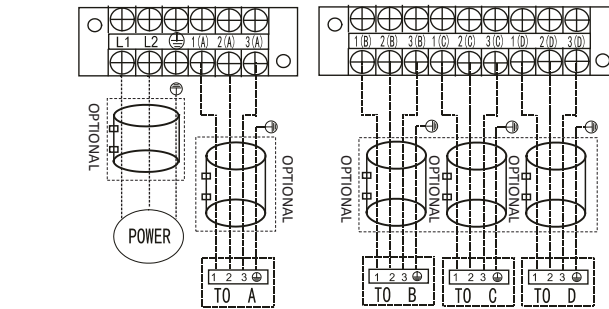

Model D

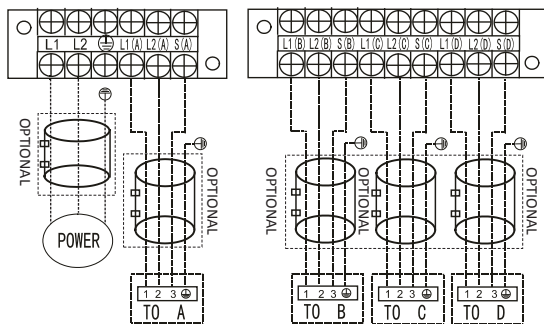

Model E

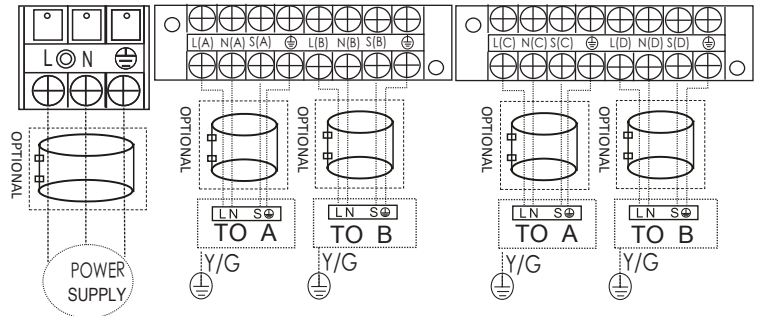

Model F

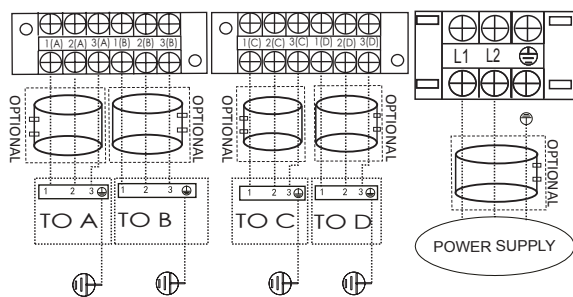

Model G

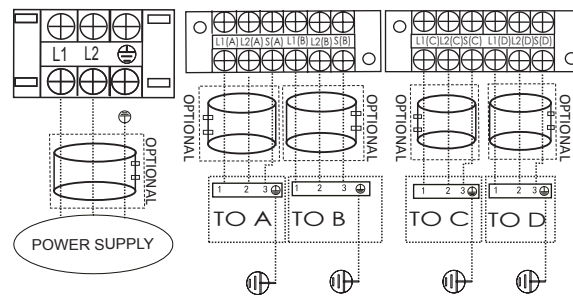

Model H

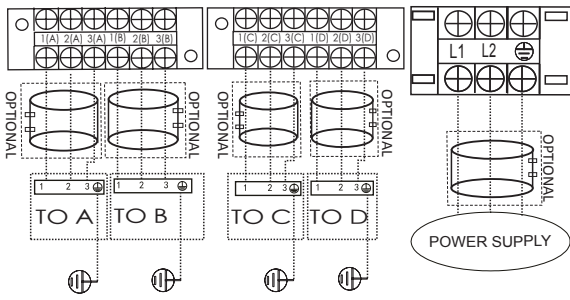

Model I

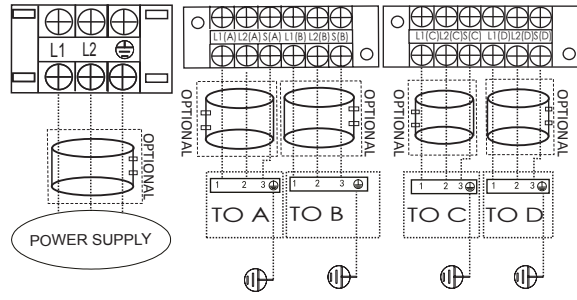

Model J

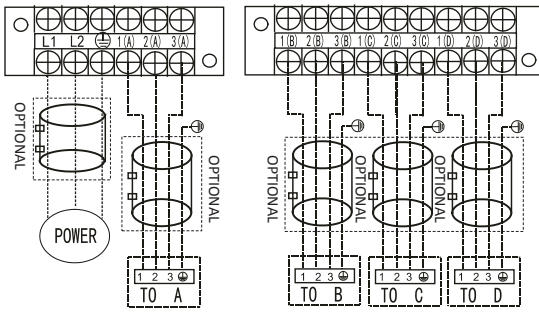

Mode K

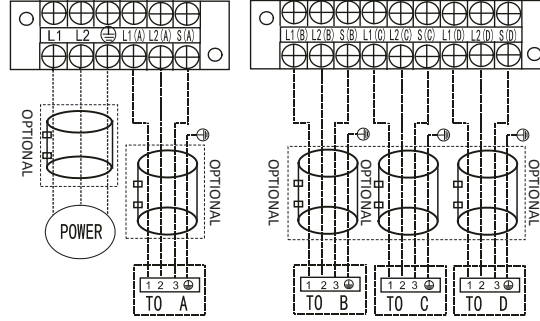

Model L

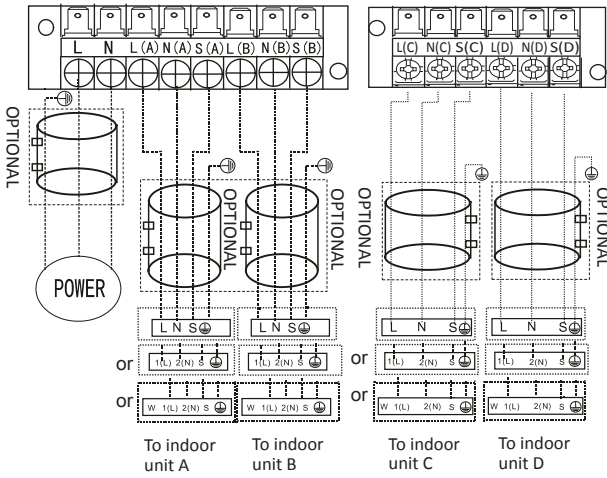

Model M

One-five models:

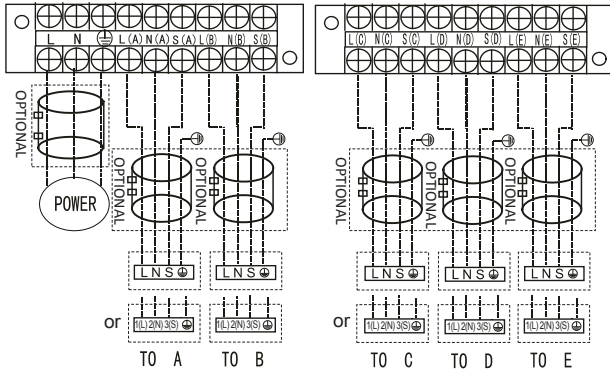

Model A

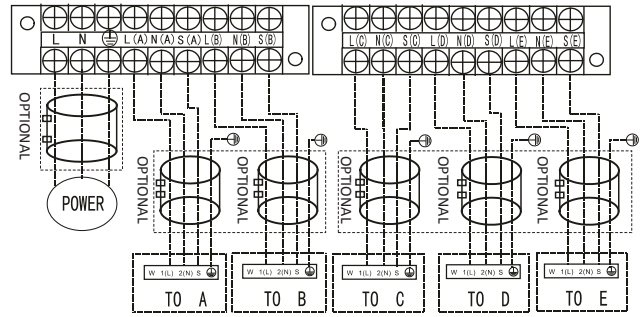

Model B

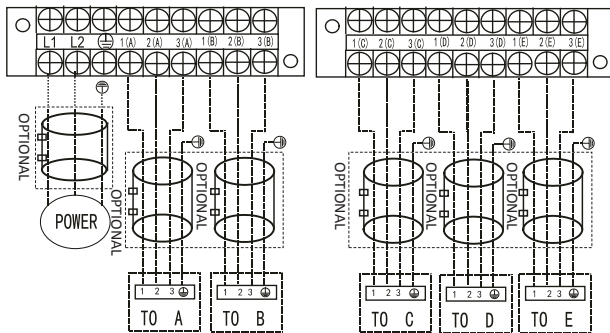

Model C

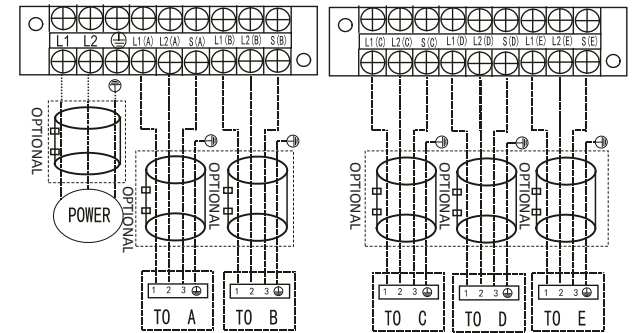

Model D

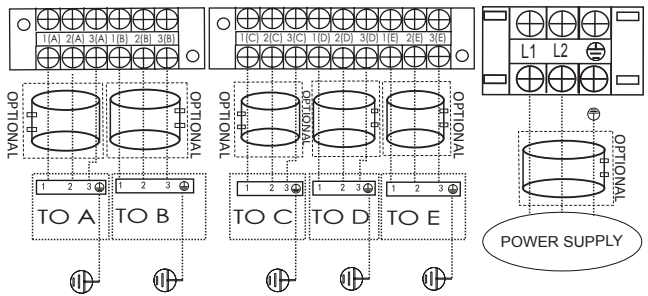

Model E

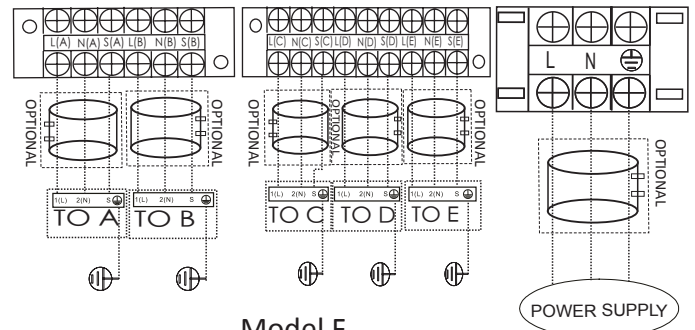

Model F

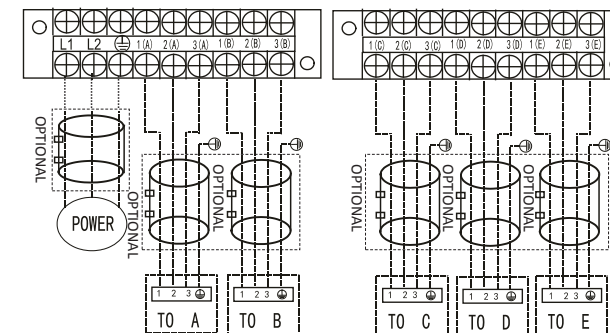

Model G

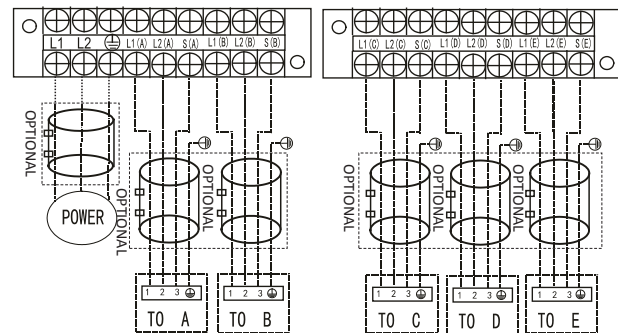

Model H

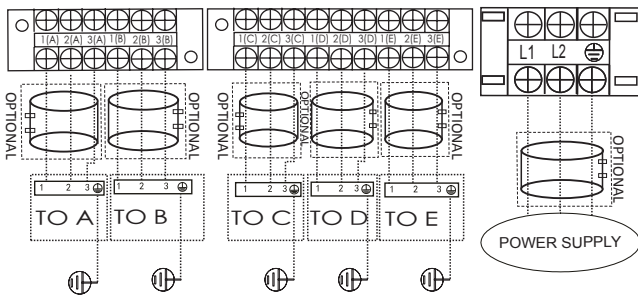

Model I

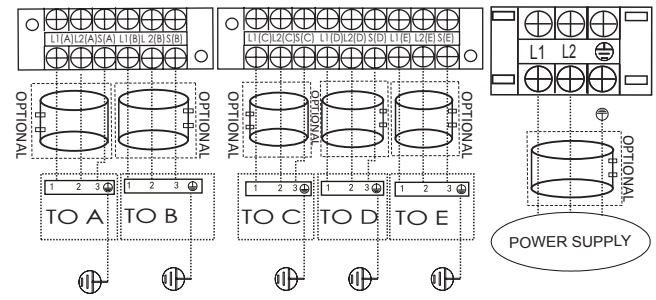

Model J

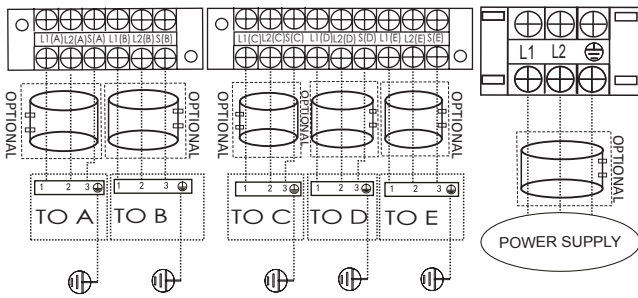

Model K

⚠ CAUTION

After confirmation of the above conditions, follow these guidelines when performing wiring:

- Always have an individual power circuit specifically for the air conditioner. Always follow the circuit diagram posted on the inside of the control cover.
- Screws fastening the wiring in the casing of electrical fittings may come loose during transportation. Because loose screws may cause wire burn-out, check that the screws are tightly fastened.
- Check the specifications for the power source.
- Confirm that electrical capacity is sufficient.
- Confirm that starting voltage is maintained at more than 90 percent of the rated voltage marked on the name plate.
- Confirm that the cable thickness is as specified in the power source specifications.
- Always install an earth leakage circuit breaker in wet or moist areas.
- The following can be caused by a drop in voltage: vibration of a magnetic switch, damaging the contact point, broken fuses, and disturbance of normal functioning.
- Disconnection from a power supply must be incorporated into the fixed wiring. It must have an air gap contact separation of at least 0.11in (3mm) in each active (phase) conductors.
- Before accessing terminals, all supply circuits must be disconnected.

NOTE:

To satisfy the EMC compulsory regulations, which is required by the international standard CISPR 14-1:2005/A2:2011 in specific countries or districts, please make sure you apply the correct magnetic rings on your equipment according to the wiring diagram that adhere to the your equipment.

Please contact your distributor or installer to get further information and purchase magnetic rings (The supplier of magnetic ring is TDK (model ZCAT3035-1330) or similar).

Air Evacuation

Preparations and Precautions

Air and foreign matter in the refrigerant circuit can cause abnormal rises in pressure, which can damage the air conditioner, reduce its efficiency, and cause injury. Use a vacuum pump and manifold gauge to evacuate the refrigerant circuit, removing any non-condensable gas and moisture from the system.

Evacuation should be performed upon initial installation and when unit is relocated.

BEFORE PERFORMING EVACUATION

- ✓ Check to make sure the connective pipes between the indoor and outdoor units are connected properly .
- ✓ Check to make sure all wiring is connected

Evacuation Instructions

Before using a manifold gauge and a vacuum pump, read their operation manuals to make sure you know how to use them properly.

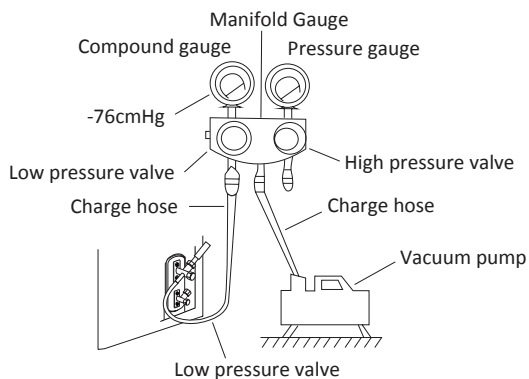

1. Connect the manifold gauge's charge hose to the service port on the outdoor unit's low pressure valve.
2. Connect the manifold gauge's charge hose from the to the vacuum pump.
3. Open the Low Pressure side of the manifold gauge. Keep the High Pressure side closed.
4. Turn on the vacuum pump to evacuate the system.
5. Run the vacuum for at least 15 minutes, or until the Compound Meter reads -76cmHG (-1x105Pa).
6. Close the manifold gauge's Low Pressure valve and turn off the vacuum pump.
7. Wait for 5 minutes, then check that there has been no change in system pressure.

NOTE: If there is no change in system pressure, unscrew the cap from the packed valve (high pressure valve). If there is a change in system pressure, there may be a gas leak.

8. Insert hexagonal wrench into the packed valve (high pressure valve) and open the valve by turning the wrench 1/4 counterclockwise. Listen for gas to exit the system, then close the valve after 5 seconds.

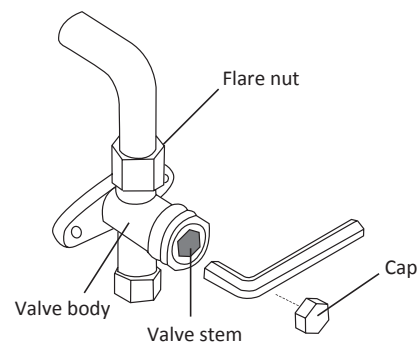

9. Watch the Pressure Gauge for one minute to make sure that there is no change in pressure. It should read slightly higher than the atmospheric pressure.
10. Remove the charge hose from the service port.
11. Using hexagonal wrench, fully open both the high pressure and low pressure valves.

OPEN VALVE STEMS GENTLY

When opening valve stems, turn the hexagonal wrench until it hits against the stopper. **DO NOT** try to force the valve to open further.

12. Tighten valve caps by hand, then tighten it using the proper tool.
13. If the outdoor unit uses all vacuum valves, and the vacuum position is at the main valve, the system is not connected with the indoor unit. The valve must be tightened with a screw nut. Check for gas leaks before operation to prevent leakage.

Note On Adding Refrigerant

CAUTION

- Refrigerant charging must be performed after wiring, vacuuming, and the leak testing.
- **DO NOT** exceed the maximum allowable quantity of refrigerant or overcharge the system. Doing so can damage the unit or impact it's functioning.
- Charging with unsuitable substances may cause explosions or accidents. Ensure that the appropriate refrigerant is used.
- Refrigerant containers must be opened slowly. Always use protective gear when charging the system.
- **DO NOT** mix refrigerants types.
- For the R290 or R32 refrigerant model, make sure the conditions within the area have been made safe by control of flammable material when the refrigerant added into air conditioner.

N=2(one-twin models), N=3(one-three models), N=4(one-four models), N=5(one-five models). Depending on the length of connective piping or the pressure of the evacuated system, you made need to add refrigerant. Refer to table below for refrigerant amounts to be added:

ADDITIONAL REFRIGERANT PER PIPE LENGTH

Connective Pipe Length(m)	Air Purging Method	Additional Refrigerant	
Pre-charge pipe length (ft/m) (pre-charge pipe length xN)	Vacuum Pump	N/A	
More than (pre-charge pipe lengthxN) ft/m	Vacuum Pump	Liquid Side: \varnothing 1/4" (\varnothing 6.35) R32 (Total pipe length - pre-charge pipe lengthxN) x12g/m (Total pipe length - pre-charge pipe lengthxN) x0.13oz/ft	Liquid Side: \varnothing 3/8" (\varnothing 9.52) R32 (Total pipe length - pre-charge pipe lengthxN) x24g/m (Total pipe length - pre-charge pipe lengthxN) x0.26oz/ft
		Liquid Side: \varnothing 1/4" (\varnothing 6.35) R410A (Total pipe length - pre-charge pipe lengthxN) x15g/m (Total pipe length - pre-charge pipe lengthxN) x0.16oz/ft	Liquid Side: \varnothing 3/8" (\varnothing 9.52) R410A (Total pipe length - pre-charge pipe lengthxN) x30g/m (Total pipe length - pre-charge pipe lengthxN) x0.32oz/ft

NOTE: The standard pipe length is 24.6 ft.

ADDITIONAL REFRIGERANT FOR INDOOR MODELS

When the one-five model is equipped with the following AHU indoor unit, additional refrigerant shall be added.

Indoor Unit Model	Amount Of Refrigerant
30000Btu/h	17.6 oz (0.5 kg)
36000Btu/h	

Safety And Leakage Check

Electrical safety check

Perform the electrical safety check after completing installation. Cover the following areas:

1. Insulated resistance
The insulated resistance must be more than $2M\Omega$.
2. Grounding work
After finishing grounding work, measure the grounding resistance by visual detection and using the grounding resistance tester. Make sure the grounding resistance is less than 4Ω .
3. Electrical leakage check (performing during test while unit is on)
During a test operation after completed installation, the use the electroprobe and multimeter to perform an electrical leakage check. Turn off the unit immediately if leakage happens. Try and evaluate different solutions until the unit operates properly.

Gas leak check

1. Soap water method:
Apply a soap-water solution or a liquid neutral detergent on the indoor unit connection or outdoor unit connections with a soft brush to check for leakage of the connecting points of the piping. If bubbles emerge, the pipes are experiencing leakage.
2. Leak detector
Use the leak detector to check for leakage.

NOTE: The illustration is for example purposes only. The actual order of A, B, C, D, and E on the machine may be slightly different from the unit you purchased but the general shape will remain the same.

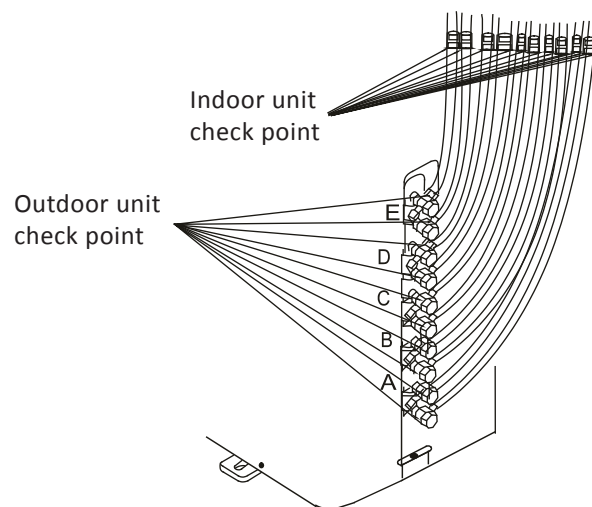

A, B,C,D are points for one-four type.
A, B,C,D, and E are points for the one-five type.

Test Run

Before Test Run

A test run must be performed after the entire system has been completely installed. Confirm the following points before performing the test:

- a) The indoor and outdoor units are properly installed.
- b) Piping and wiring are properly connected.
- c) No obstacles near the inlet and outlet of the unit that might cause poor performance or product malfunction.
- d) The refrigeration system does not leak.
- e) Drainage system is unimpeded and draining to a safe location.
- f) The heating insulation is properly installed.
- g) The grounding wires are properly connected.
- h) Length of the piping and additional refrigerant stow capacity have been recorded.
- i) The power voltage is the correct voltage for the air conditioner.

- f. Check to see that the drainage system is unimpeded and draining smoothly.
 - g. Ensure there is no vibration or abnormal noise during operation.
5. For the Outdoor Unit
- a. Check to see if the refrigeration system is leaking.
 - b. Make sure there is no vibration or abnormal noise during operation.
 - c. Ensure the wind, noise, and water generated by the unit do not disturb your neighbors or pose a safety hazard.

NOTE: If the unit malfunctions or does not operate according to your expectations, please refer to the Troubleshooting section of the Owner's Manual before calling customer service.

CAUTION

Failure to perform the test run may result in unit damage, property damage or personal injury.

Test Run Instructions

1. Open both the liquid and gas stop valves.
2. Turn on the main power switch and allow the unit to warm up.
3. Set the air conditioner to COOL mode.
4. For the Indoor Unit
 - a. Ensure the remote control and its buttons work properly.
 - b. Ensure the louvers move properly and can be changed using the remote control.
 - c. Double check to see if the room temperature is being registered correctly.
 - d. Ensure the indicators on the remote control and the display panel on the indoor unit work properly.
 - e. Ensure the manual buttons on the indoor unit works properly.

Function of Automatic Wiring/Piping Correction

Automatic Wiring/Piping Correction Function

More recent models now feature automatic correction of wiring/piping errors. Press the "check switch" on the outdoor unit PCB board for 5 seconds until the LED displays "CE", indicating that this function is working. Approximately 5-10 minutes after the switch is pressed, the "CE" disappears, meaning that the wiring/piping error is corrected and all wiring/piping is properly connected.

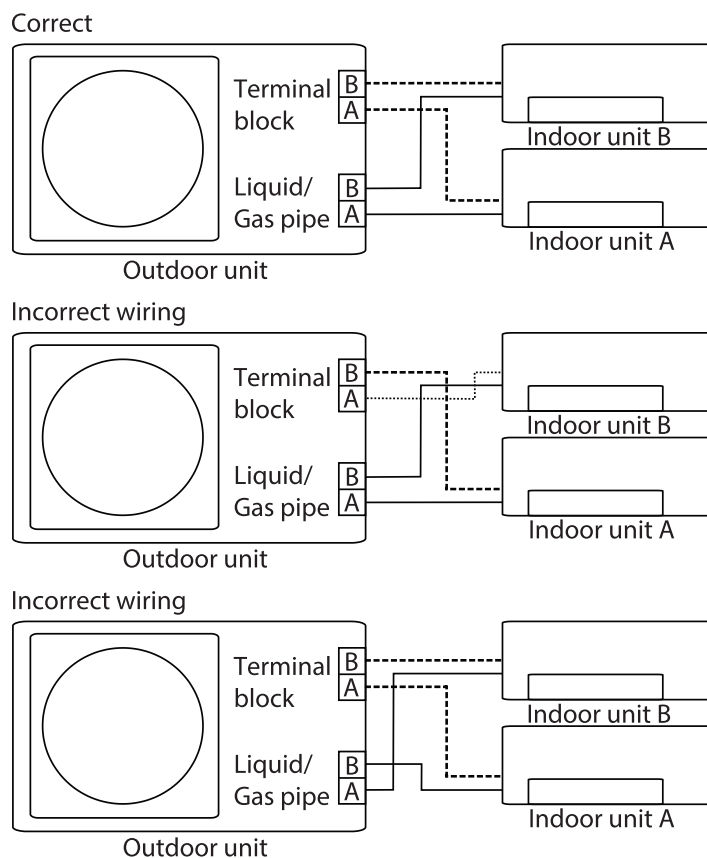
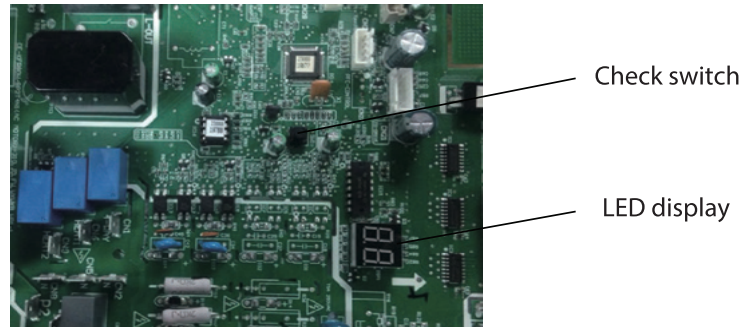

How To Activate This Function

1. Check that outside temperature is above 5 °C.
(This function does not work when outside temperature is not above 5 °C)
2. Check that the stop valves of the liquid pipe and gas pipe are open.
3. Turn on the breaker and wait at least 2 minutes.
4. Press the check switch on the outdoor PCB board unit LED display "CE".

The design and specifications are subject to change without prior notice for product improvement. Consult with the sales agency or manufacturer for details. Any updates to the manual will be uploaded to the service website, please check for the latest version.

QS003UI-YTD