

**Job Name:** \_\_\_\_\_  
**Location:** \_\_\_\_\_  
**Engineer:** \_\_\_\_\_  
**Submitted to:** \_\_\_\_\_  
**Submitted by:** \_\_\_\_\_  
**Reference:** \_\_\_\_\_

**Date:** \_\_\_\_\_  
**Approval:** \_\_\_\_\_  
**Construction:** \_\_\_\_\_  
**Unit #:** \_\_\_\_\_  
**Drawing #:** \_\_\_\_\_

## KEY FEATURES:

- Flexible Installation
- Compatible with Regular or Hyper Heat Pump
- SmartPort Ready
- Wall Thermostat Included
- Remote Control Included

## NOTES:

\_\_\_\_\_  
 \_\_\_\_\_  
 \_\_\_\_\_  
 \_\_\_\_\_  
 \_\_\_\_\_



## Slim Duct

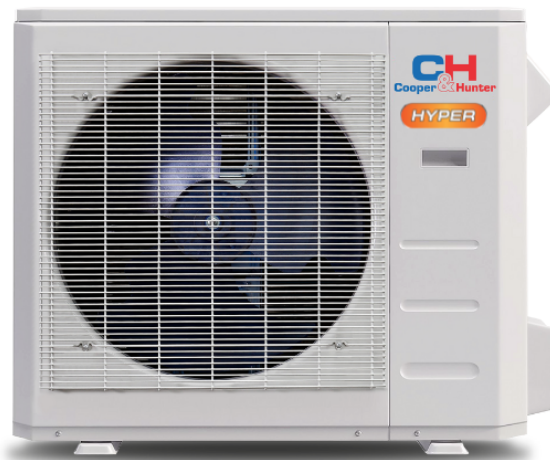
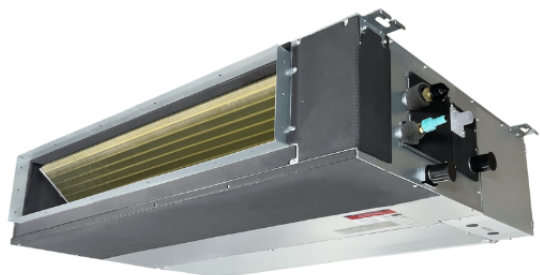

Indoor Model			CH-M24DTUI
Power supply		V, Ph, Hz	208-230V, 1Ph, 60Hz
Communication wiring			14AWG*4
Cooling	Capacity	Btu/h	24,000(6,500~27,800)
	Input	w	2,000(280~2,400)
	Rated current	A	8.52(2.1~11.0)
	EER/EER2	Btu/w	12
	SEER/SEER2	Btu/w	19.2
Heating at 47 °F	Capacity	Btu/h	25,000(12,200~32,200)
	Input	W	2,220(670~2,500)
	Rated current	A	8.19(4.6~11.3)
	COP	W/W	3.3
	HSPF4/HSPF2-4		10.5
	HSPF5/HSPF2-5		8.8
Indoor fan motor		Qty	1
		Input	90
		RLA	1.5
Indoor air flow (Turbo/Hi/Med/Lo) (No duct)		CFM	775.47/775.47/693.06/434.88
ESP (range)		In.wg.	0-0.64
Indoor noise level (Hi/Med/Lo)		dB(A)	44/40/35.5
Dehumidification		L/H	3.38
Indoor unit	Dimensions (WxDxH)	inch	43.31x30.47x9.80
	Packing (WxDxH)	inch	51.38x31.69x12.40
	Net/Gross weight	lbs	90.39/105.82
Drainage water pipe diameter		inch	1"
Refrigerant piping (Liquid side/Gas side)		inch	3/8"/5/8"
Design pressure		PSIG	550/340
Controller			RG10K-exclusive remote&120X or 120N wire controller
Room temperature	Cooling	F	62~90
	Heating	F	32~86

Outdoor Model			CH-HPR24-230VO
Power supply		V, Ph, Hz	208-230V, 1Ph, 60Hz
Min. circuit ampacity		A	25
Max. fuse		A	35
Compressor	Model		KTM240D43UKT
	Type		Twin-ROTARY
	Brand		GMCC
	Capacity	Btu/h	25,930
	Input	w	2,045
	Rated current (RLA)	A	17.1
	Refrigerant oil	oz	VG74 21
Outdoor fan motor	Qty		1
	Input	w	150
	RLA	A	0.5
	Speed	r/min	950/800/500
Outdoor air flow (Max)		CFM	2,235.29
Outdoor noise level (Max)		dB(A)	62
Throttle type			EXV+Throttle valve
Outdoor unit	Dimensions (WxDxH)	inch	37.24x16.14x31.89
	Packing (WxDxH)	inch	42.91x19.69x34.84
	Net/Gross weight	inch	134.48/144.40
Refrigerant	Type		R410A
	Precharge	ft	25
Additional charge for 1/4 inch liquid pipe		oz	
Additional charge for 3/8 inch liquid pipe		oz	0.32
Refrigerant piping	Liquid side/Gas side	inch	3/8"/5/8"
	Max. pipe length	ft	164.04
	Max. difference in level	ft	82.02
Ambient temperature	Cooling	F	-22 ~ 122
	Heating	F	-22 ~ 75

CH-M24DTUI

Unit: inch

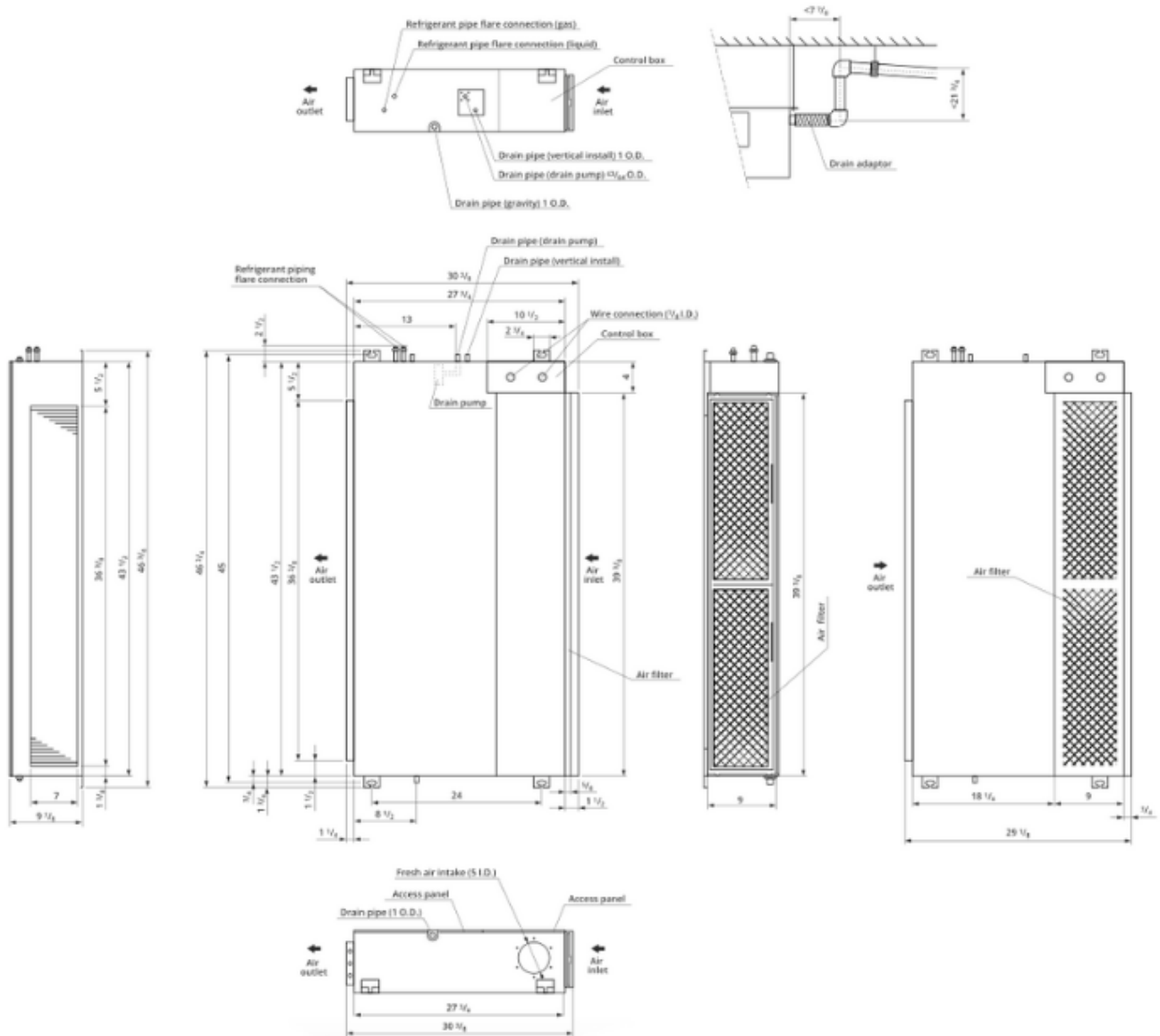

43.31x30.47x9.80

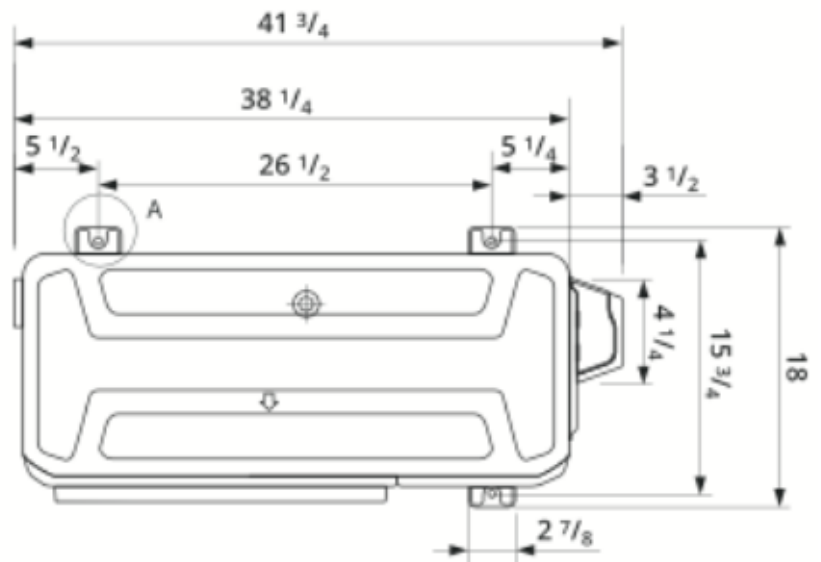
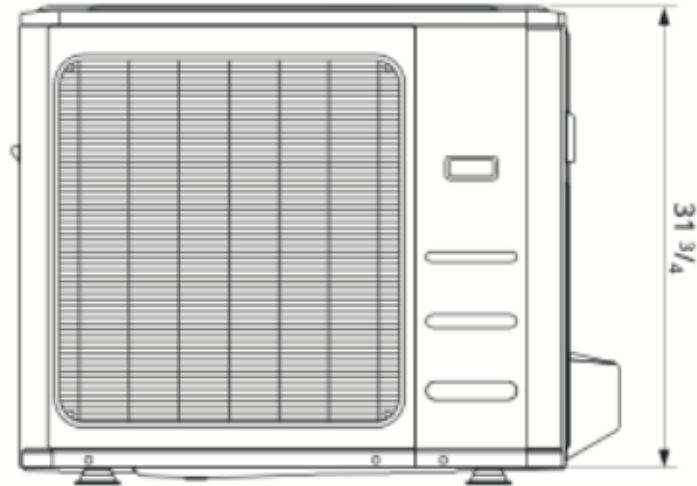
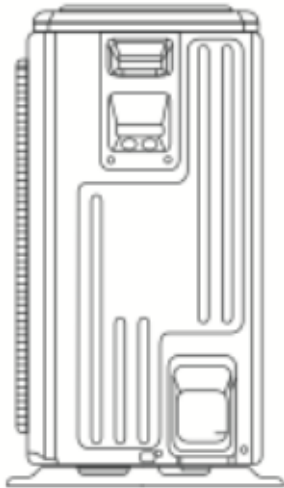

**DETAIL A**  
**SCALE 1:1**

