

**Job Name:** \_\_\_\_\_  
**Location:** \_\_\_\_\_  
**Engineer:** \_\_\_\_\_  
**Submitted to:** \_\_\_\_\_  
**Submitted by:** \_\_\_\_\_  
**Reference:** \_\_\_\_\_

**Date:** \_\_\_\_\_  
**Approval:** \_\_\_\_\_  
**Construction:** \_\_\_\_\_  
**Unit #:** \_\_\_\_\_  
**Drawing #:** \_\_\_\_\_

### KEY FEATURES:

- Two-way Draining Connection
- Activated Carbon Filter
- GoldFin Anti-Corrosive Coating
- Omni-Directional Airflow
- 12 Indoor Fan Speeds
- Refrigerant Leakage Detection
- Self Diagnosis Function
- Fresh Air Intake

### NOTES:

\_\_\_\_\_  
 \_\_\_\_\_  
 \_\_\_\_\_  
 \_\_\_\_\_  
 \_\_\_\_\_



### CEILING CASSETTE



Indoor Model			CH-09MSPHCT-230VI
Power supply		V, Ph, Hz	208-230V, 1Ph, 60Hz
Communication wiring			14AWG*4
Cooling	Capacity	Btu/h	9,000(2,850~11,100)
	Input	w	692(163~1,117)
	Rated current	A	3.17(1.25~4.93)
	EER/EER2	Btu/w	13
	SEER/SEER2	Btu/w	20.5
Heating at 47 °F	Capacity	Btu/h	9,800(2,270~12,500)
	Input	W	930(149~1,371)
	Rated current	A	4.58(1.17~6.04)
	COP	W/W	3.09
	HSPF4/HSPF2-4		10.3
	HSPF5/HSPF2-5		7.8
Indoor fan motor		Qty	1
		Input	45
		RLA	0.9
Indoor air flow (Turbo/Hi/Med/Lo) (No duct)		CFM	388.5/352.94/305.88/270.59
ESP (range)		In.wg.	
Indoor noise level (Hi/Med/Lo)		dB(A)	39.5/36/32.5
Dehumidification		L/H	2.18
Indoor unit	Dimensions (WxDxH)	inch	22.44x22.44x10.24
	Packing (WxDxH)	inch	26.06x26.06x12.48
	Net/Gross weight	lbs	31.97/38.14
Drainage water pipe diameter		inch	1"
Refrigerant piping (Liquid side/Gas side)		inch	1/4"/3/8"
Design pressure		PSIG	550/340
Controller			RG10K-exclusive remote&120X or 120N wire controller
Room temperature	Cooling	F	62~90
	Heating	F	32~86

Outdoor Model			CH-HPR09-230VO
Power supply		V, Ph, Hz	208-230V, 1Ph, 60Hz
Min. circuit ampacity		A	15
Max. fuse		A	15
Compressor	Model		KTN110D42UFZ
	Type		ROTARY
	Brand		GMCC
	Capacity	Btu/h	11,820
	Input	w	885
	Rated current (RLA)	A	8.8
	Refrigerant oil	oz	VG74 11.8
Outdoor fan motor	Qty		1
	Input	w	34
	RLA	A	0.42
	Speed	r/min	850/680/450
Outdoor air flow (Max)		CFM	1,323.53
Outdoor noise level (Max)		dB(A)	55
Throttle type			EXV
Outdoor unit	Dimensions (WxDxH)	inch	31.69x12.99x21.81
	Packing (WxDxH)	inch	36.02x14.57x24.21
	Net/Gross weight	inch	74.07/80.25
Refrigerant	Type		R410A
	Precharge	ft	25
Additional charge for 1/4 inch liquid pipe		oz	0.16
Additional charge for 3/8 inch liquid pipe		oz	
Refrigerant piping	Liquid side/Gas side	inch	1/4"/3/8"
	Max. pipe length	ft	82.02
	Max. difference in level	ft	32.81
Ambient temperature	Cooling	F	-22 ~ 122
	Heating	F	-22 ~ 75

**CH-09MSPHCT-230VI**

**CEILING CASSETTE**

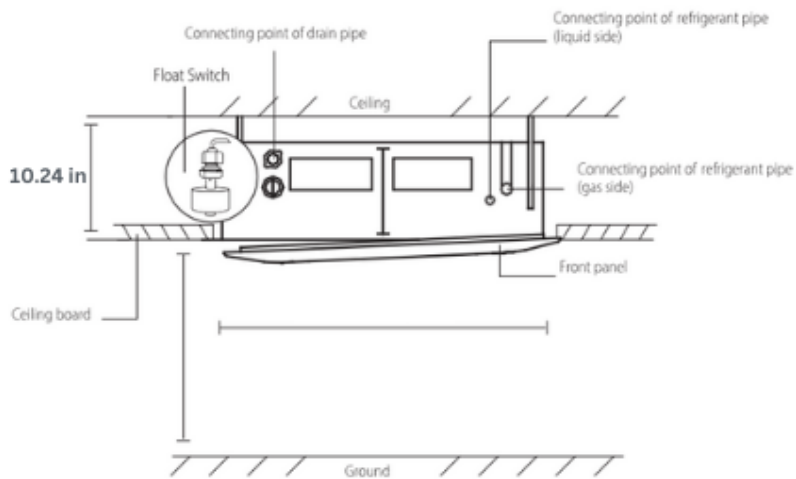
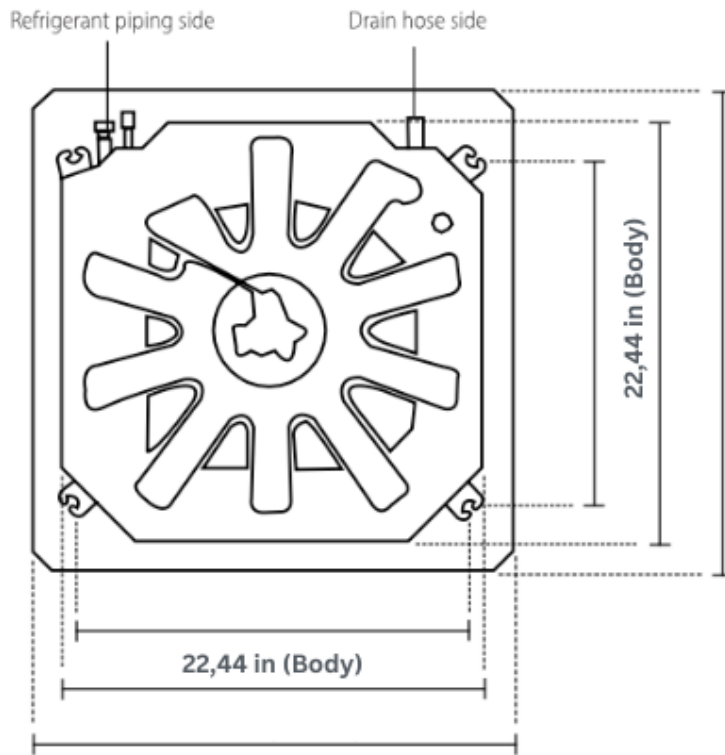

**22.44x22.44x10.24**

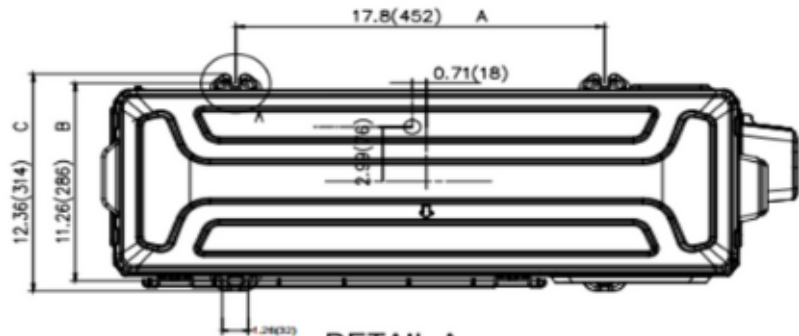
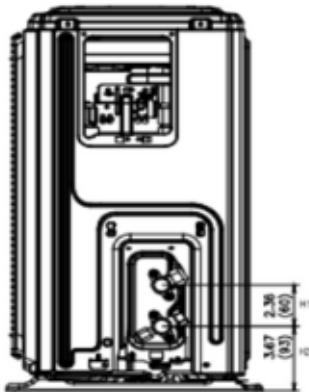
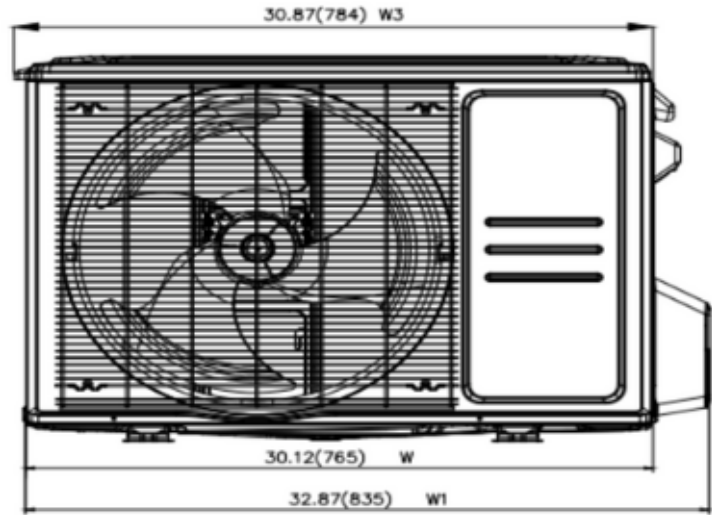
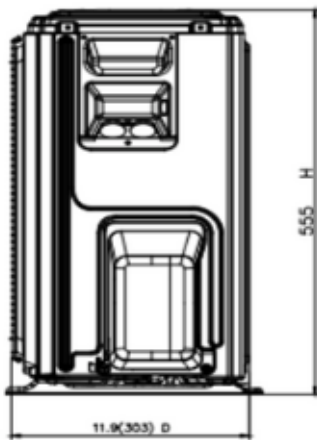

DETAIL A  
SCALE 1:2

