

SUBMITTAL DATA SHEET	CH-60LCFCI	CH-60LCUO
-----------------------------	-------------------	------------------

Job Name:
 Location:
 Engineer:
 Submitted to:
 Submitted by:
 Reference:

Date:
 Approval:
 Construction:
 Unit #:
 Drawing #:



This warranty should be registered on our web-site www.cooperandhunter.us within 60 days of installation. The warranty is only valid when installed by a Licensed HVAC Technician. A warranty period of Seven (7) years on compressor to the original registered end-user. A warranty period of Five (5) years on all parts to the original registered end user. Warranty applies only to products remaining in their original installation location.

INDOOR SPECIFICATION

Air Flow (Hi/Mi/Lo)	1385/1028/795 CFM
Noise Level (Hi/Mi/Lo)	55/39/50 dB(A)
Unit Dimension (WxDxH)	65/26.6/9.3 in
Net/Gross Weight	101.2/110 lb

OUTDOOR SPECIFICATION

Air flow	4470 CFM
Noise Level	65 dB(A)
Dimension (WxDxH)	37.5x16.3x52.5 in
Net/Gross weight	224.9/254.4 lb
Refrigerant type/Quantity	R410A/163 oz
Refrigerant precharge	25 ft
Additional charge for each ft	0.32 oz

PERFORMANCE AND EFFICIENCY

Cooling		Heating	
54,000 Btu/h		60,000 Btu/h	
SEER	18	HSPF	10.5
EER	9.8	Region IV	

Heating/Cooling	Outdoor Dry Bulb	Indoor Dry Bulb	Unit	Min	Rated	Max
Heating	5°F	70°F	Btu/h	2,753	-	33,205
			kW	1.04	-	5.24
			COP	0.78	-	1.86
	17°F	70°F	Btu/h	5,708	39,000	39,128
			kW	1.07	4.4	5.1
			COP	1.56	2.6	2.25
47°F	70°F	Btu/h	12,705	60,000	61,098	
		kW	0.7	5.57	5.47	
		COP	5.32	3.16	3.27	
Cooling	82°F	80°F	Btu/h	13,652	-	56,106
			kW	0.53	-	4.74
			COP	7.55	-	3.47
	95°F	80°F	Btu/h	16,251	54,000	54,100
			kW	1.14	5.51	5.53
			COP	4.18	2.87	2.87

OPERATION TEMPERATURE RANGE

Indoor		Outdoor	
cooling	heating	cooling	heating
62~90°F	32~86°F	5~122°F	5~86°F

ELECTRICAL

	Power supply	208-230V/ 60Hz, 1Ph
	MCA	36
	MFA	50
Outdoor fan motor	Input	126 W
	RLA	0.39 A
Compressor	Capacity	44,697 Btu/h
	Input	3,420
	RLA	23.5

MCA: Minimum Circuit Ampacity **MFA:** Max. fuse A **RLA:** Rated Load

PIPING

Refrigerant piping Liquid side/Gas side	3/8" - 3/4" in
Max. refrigerant pipe length	213 ft
Max. difference in level	98 ft

WIRING

Connection wiring	16AWG*4 Stranded, unshielded
-------------------	------------------------------

SUBMITTAL DATA SHEET	CH-60LCFCI	CH-60LCUO
----------------------	------------	-----------

INDOOR UNIT

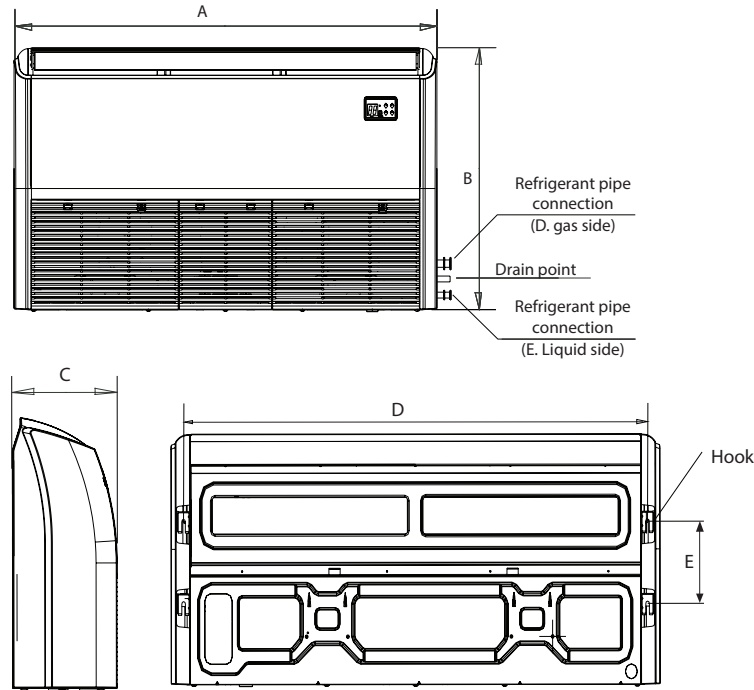

Unit Dimensions, in			Mounting Dimensions, in	
A	B	C	D	E
65	26.6	9.3	61.6	8.7

OUTDOOR UNIT

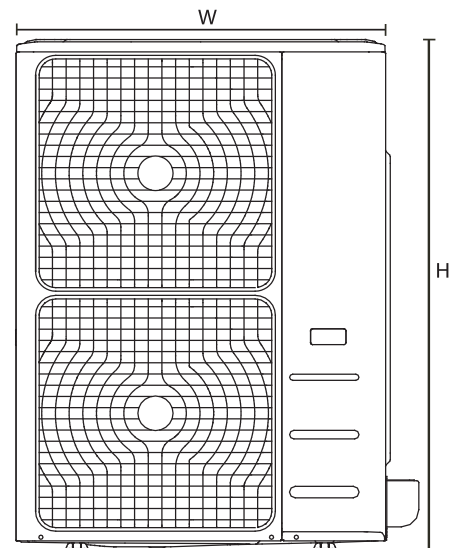
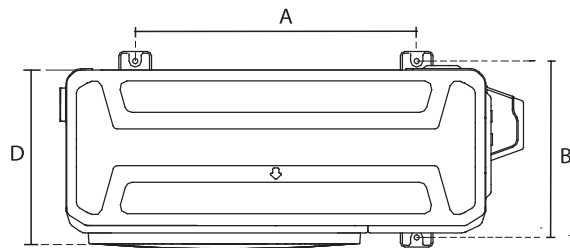

Outdoor Unit Dimensions WxDxH	Mounting Dimensions	
	Distance A	Distance B
37.5x16.3x52.5	25	15.9